

10

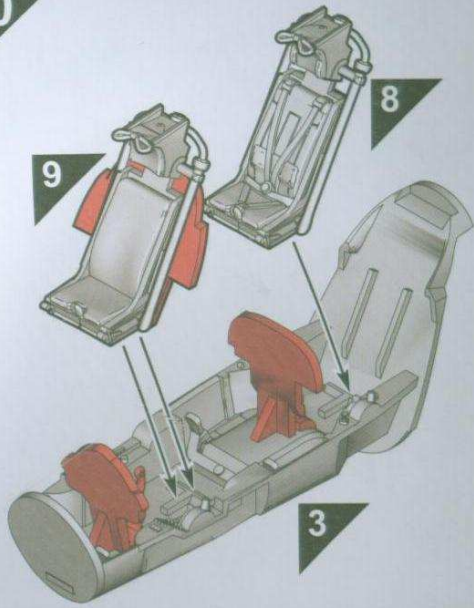

11

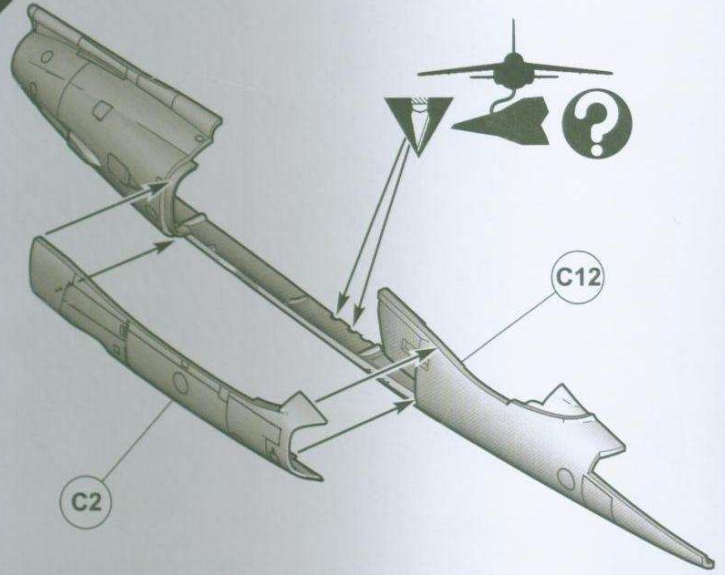

12

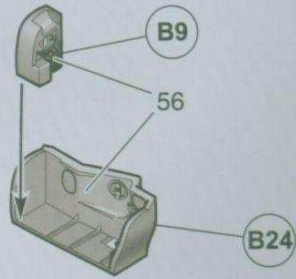

13

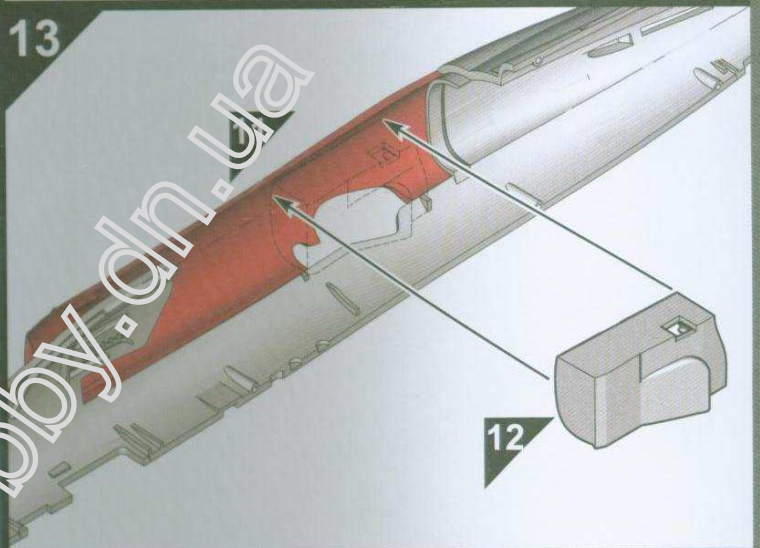

14

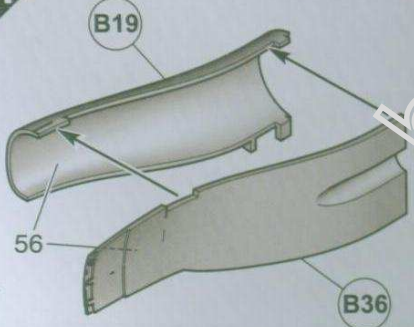

16



15

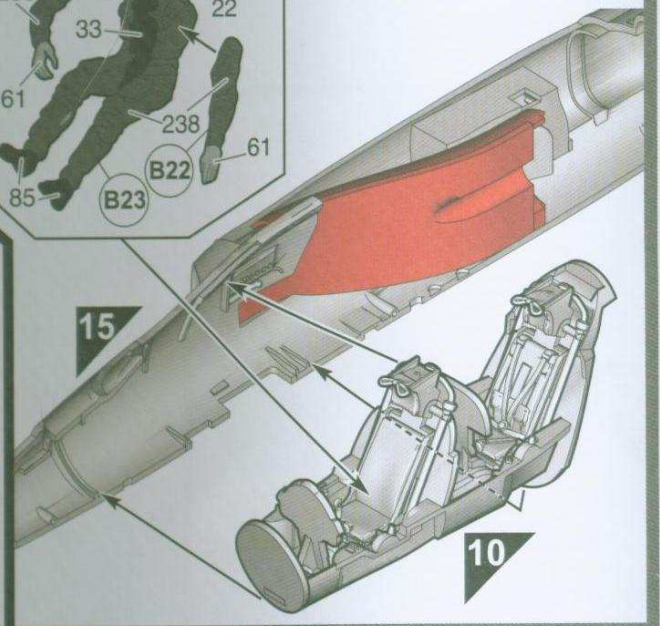
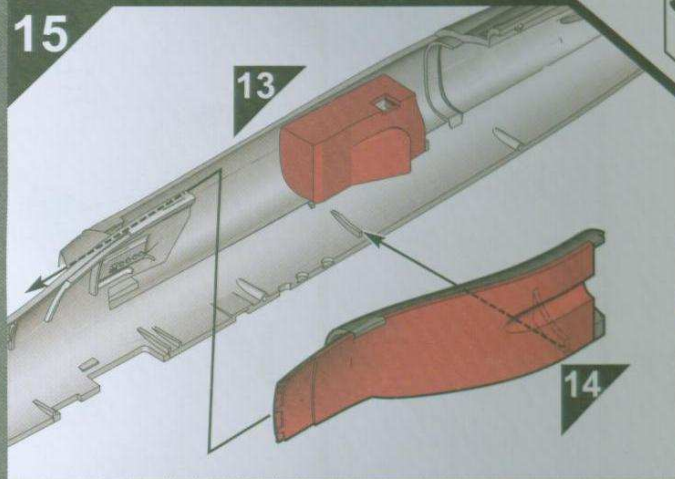

17

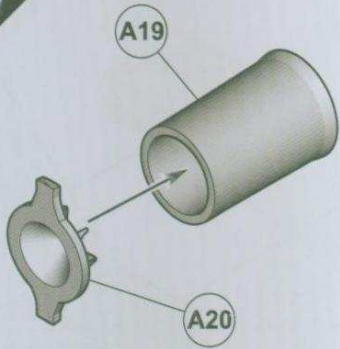

18

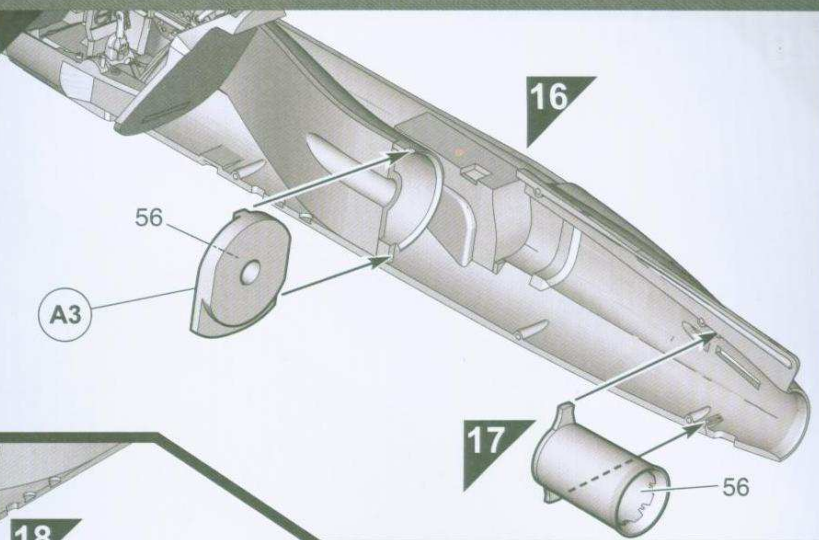

19

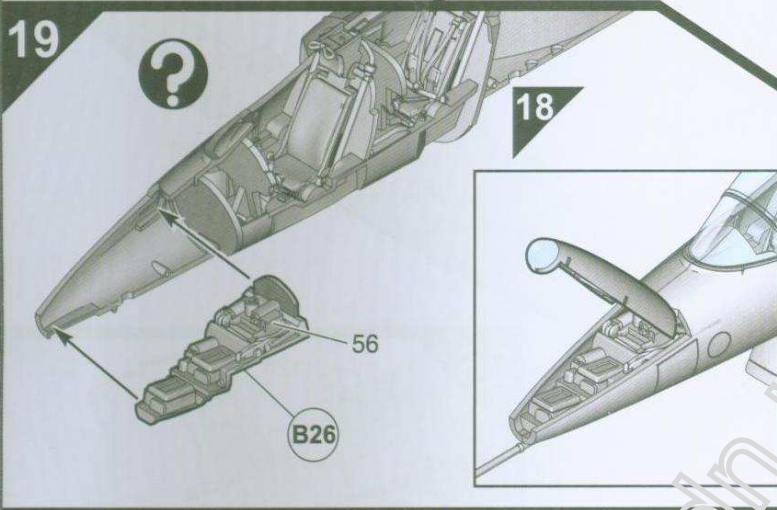

20

AF1006 AIRCRAFT STAND
SOLD SEPARATELY

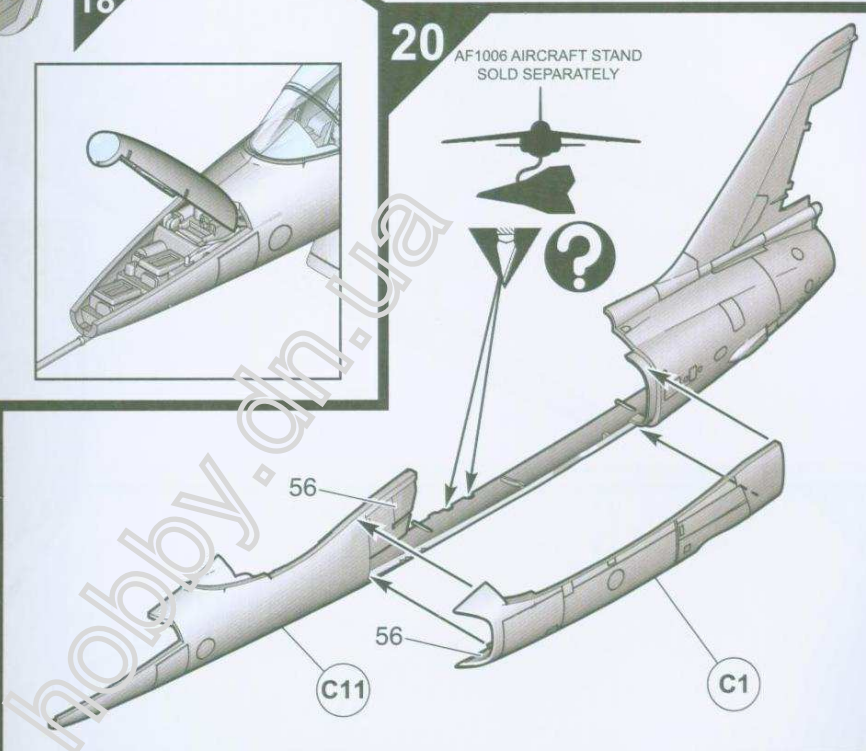

21

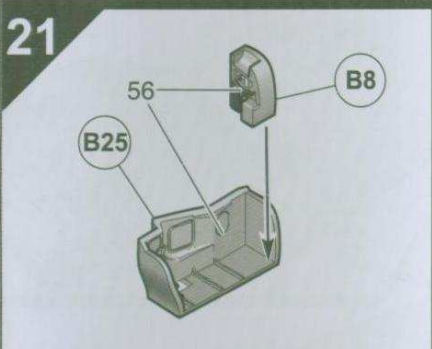

22

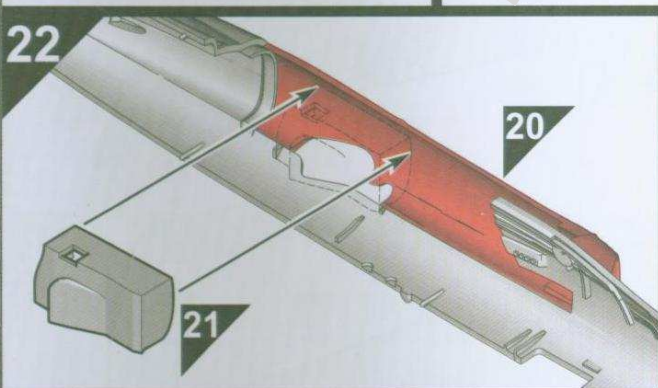

24

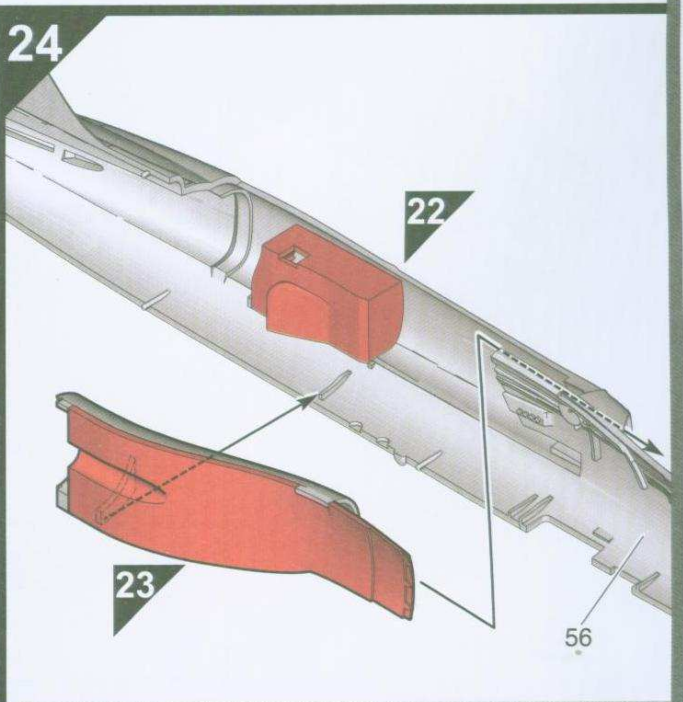

23

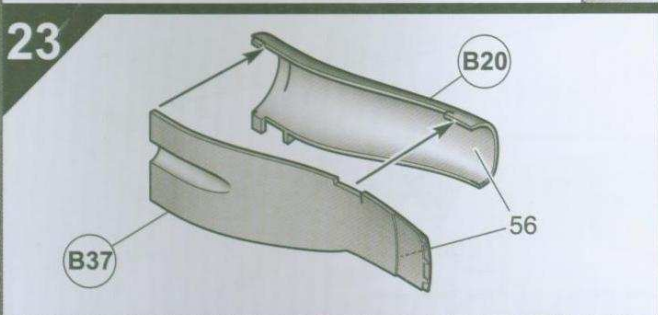

25

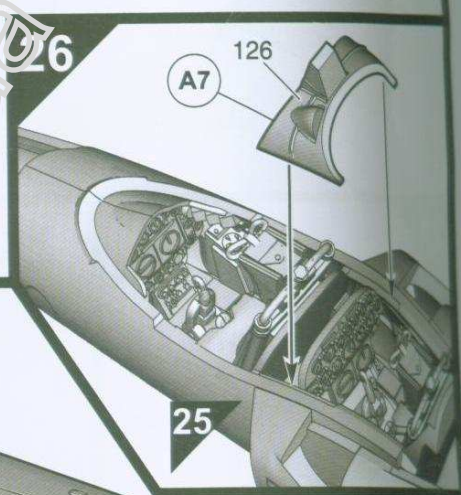
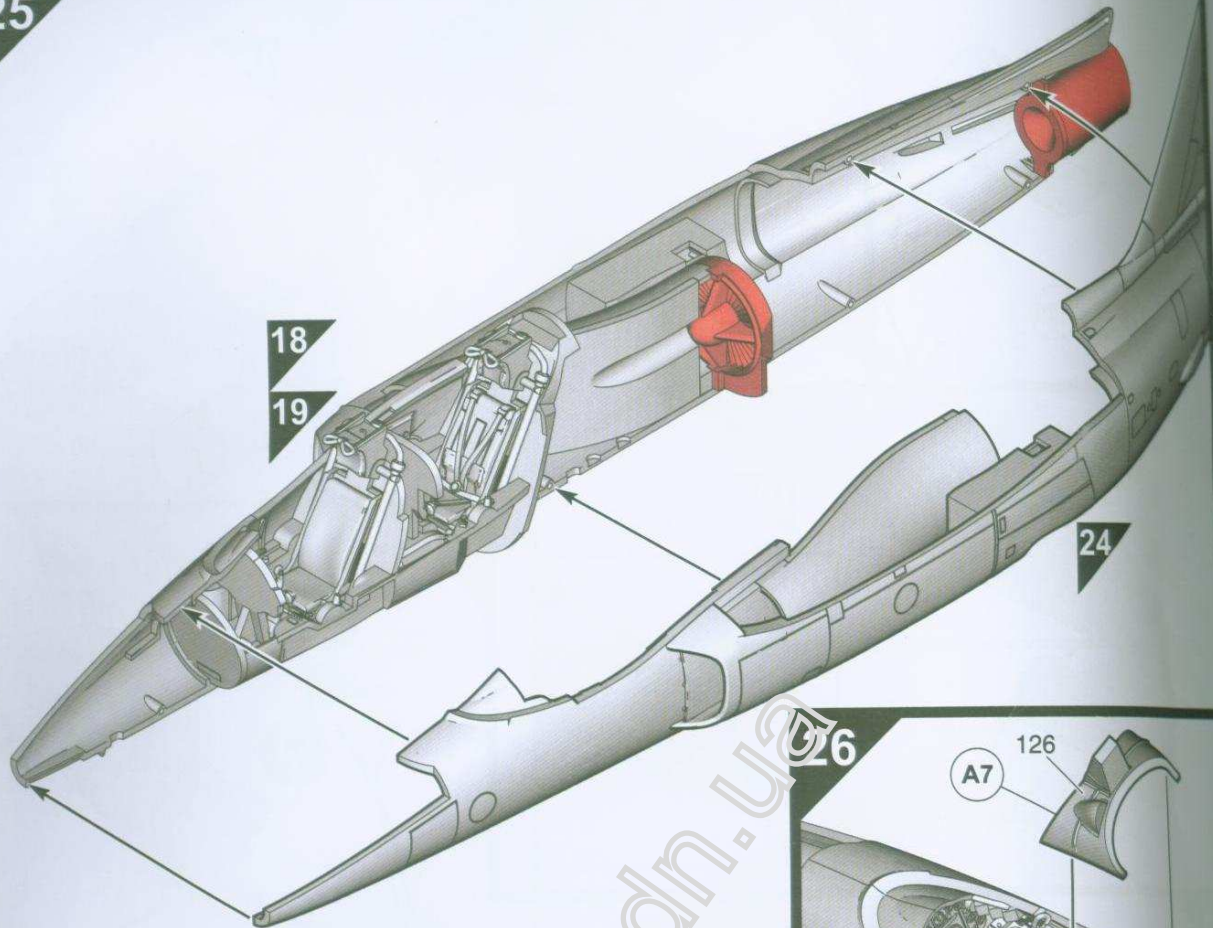

27

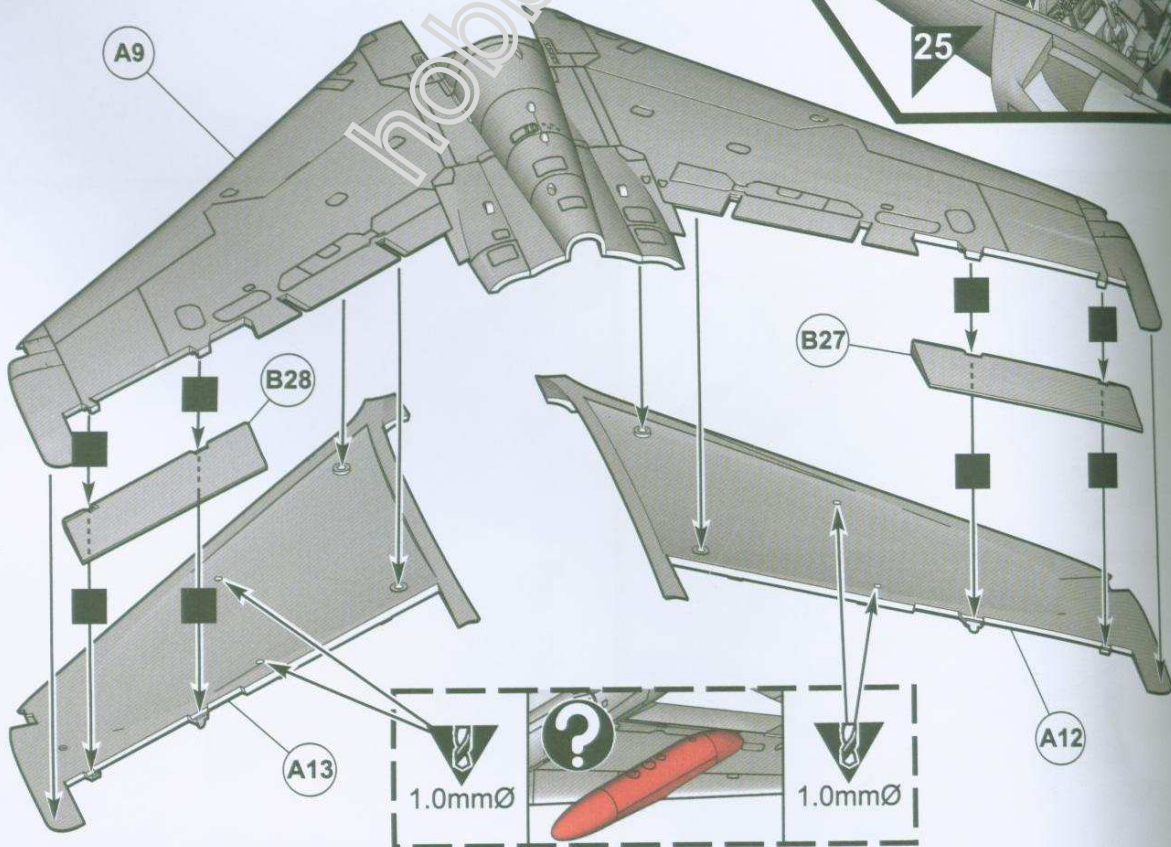

28

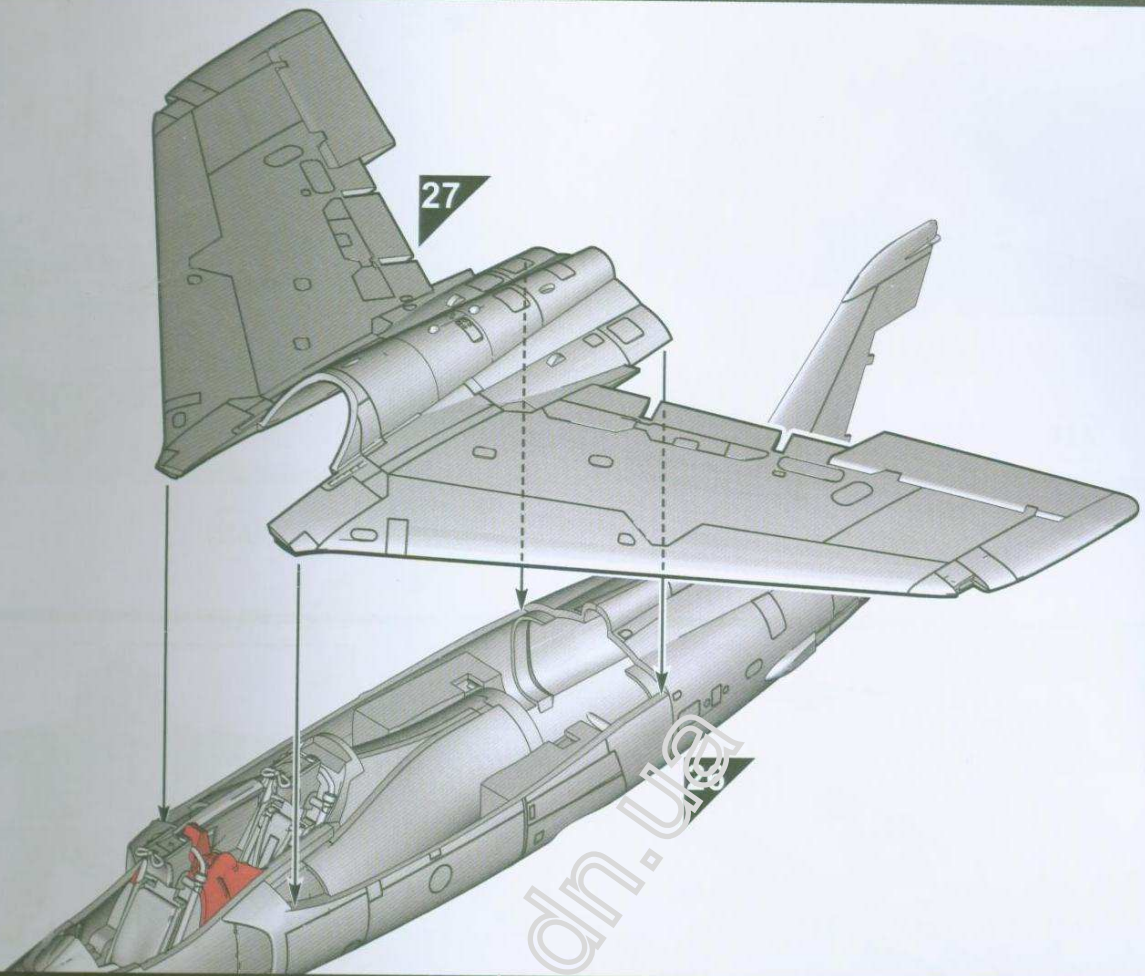

29

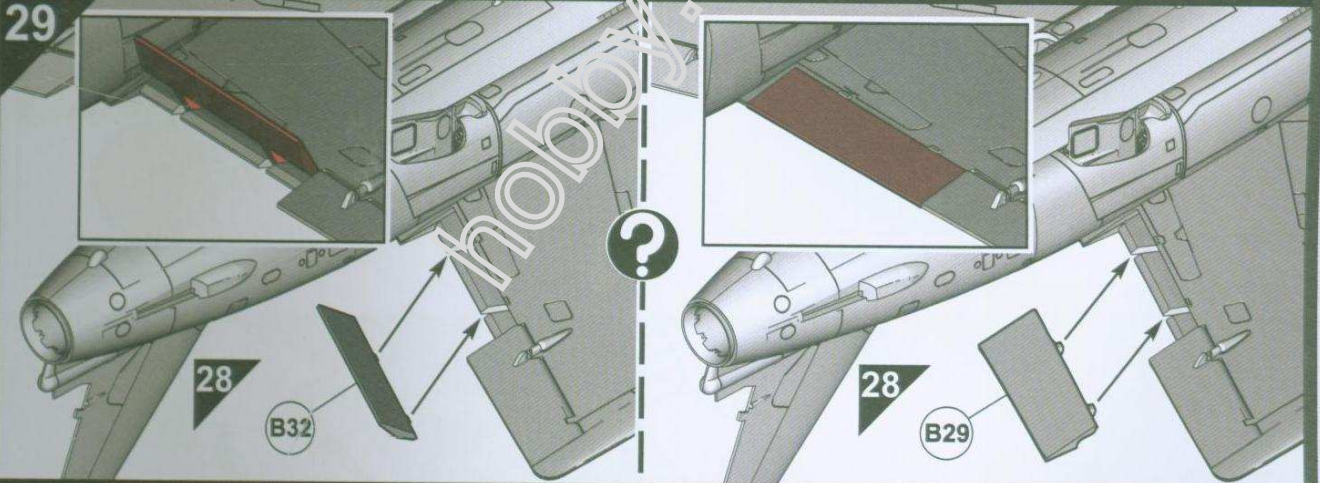

30

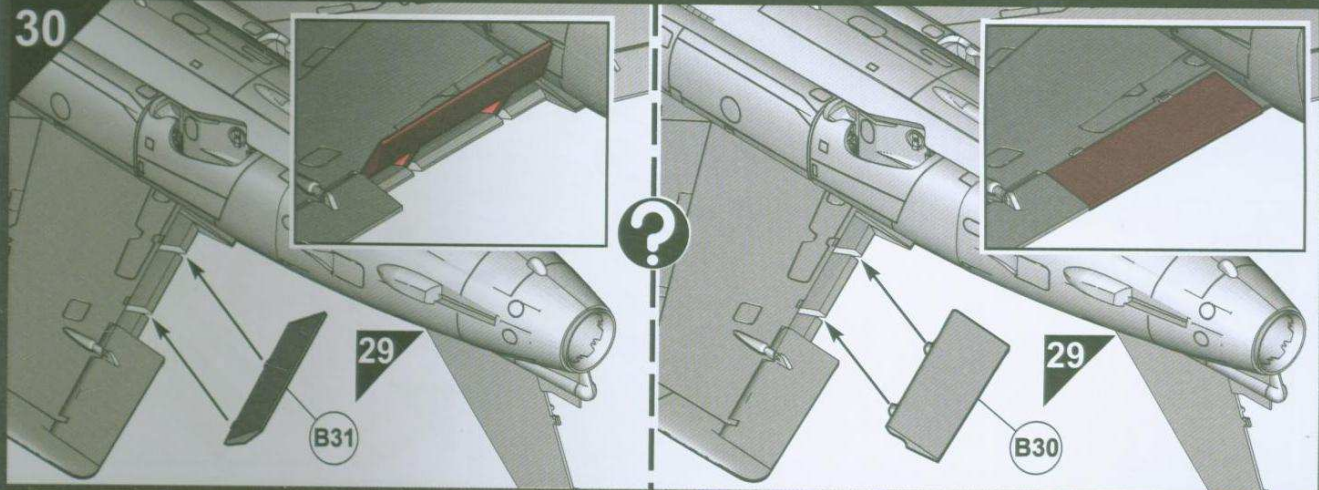

31

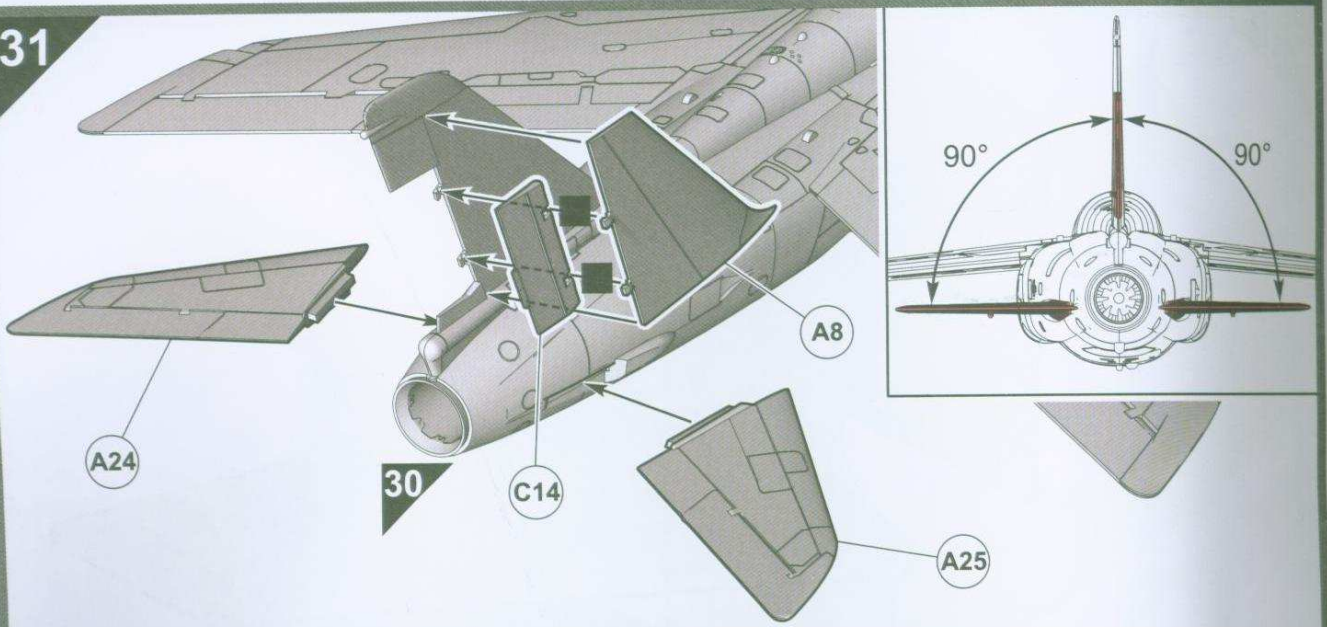

32

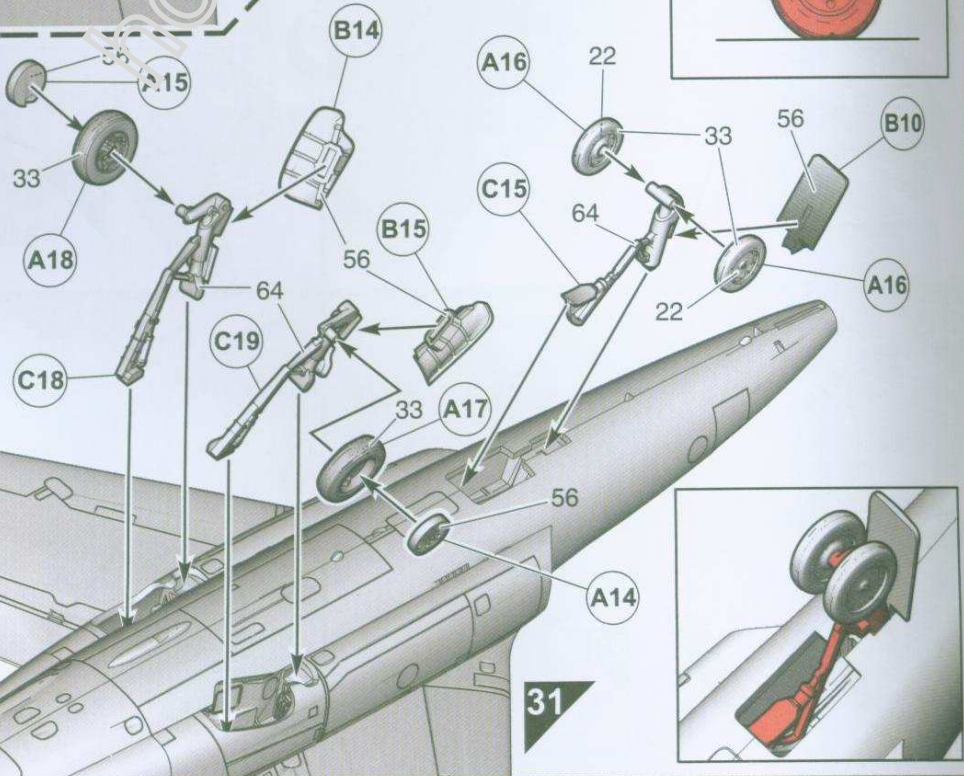
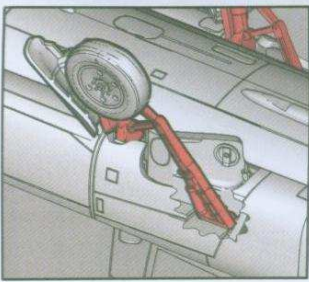
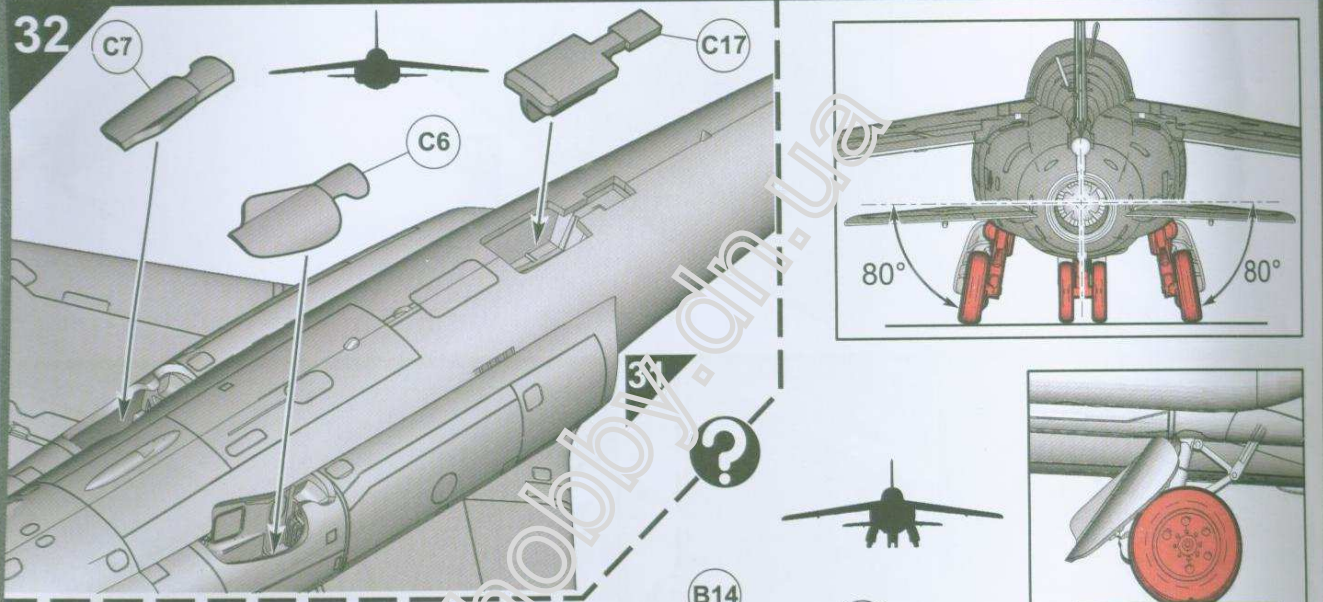

33

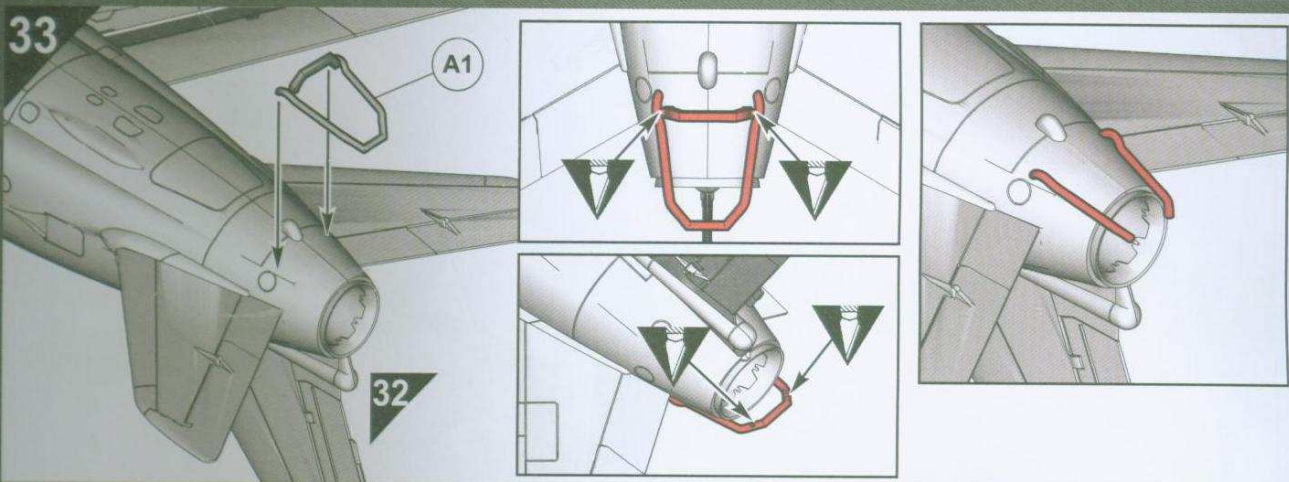

34

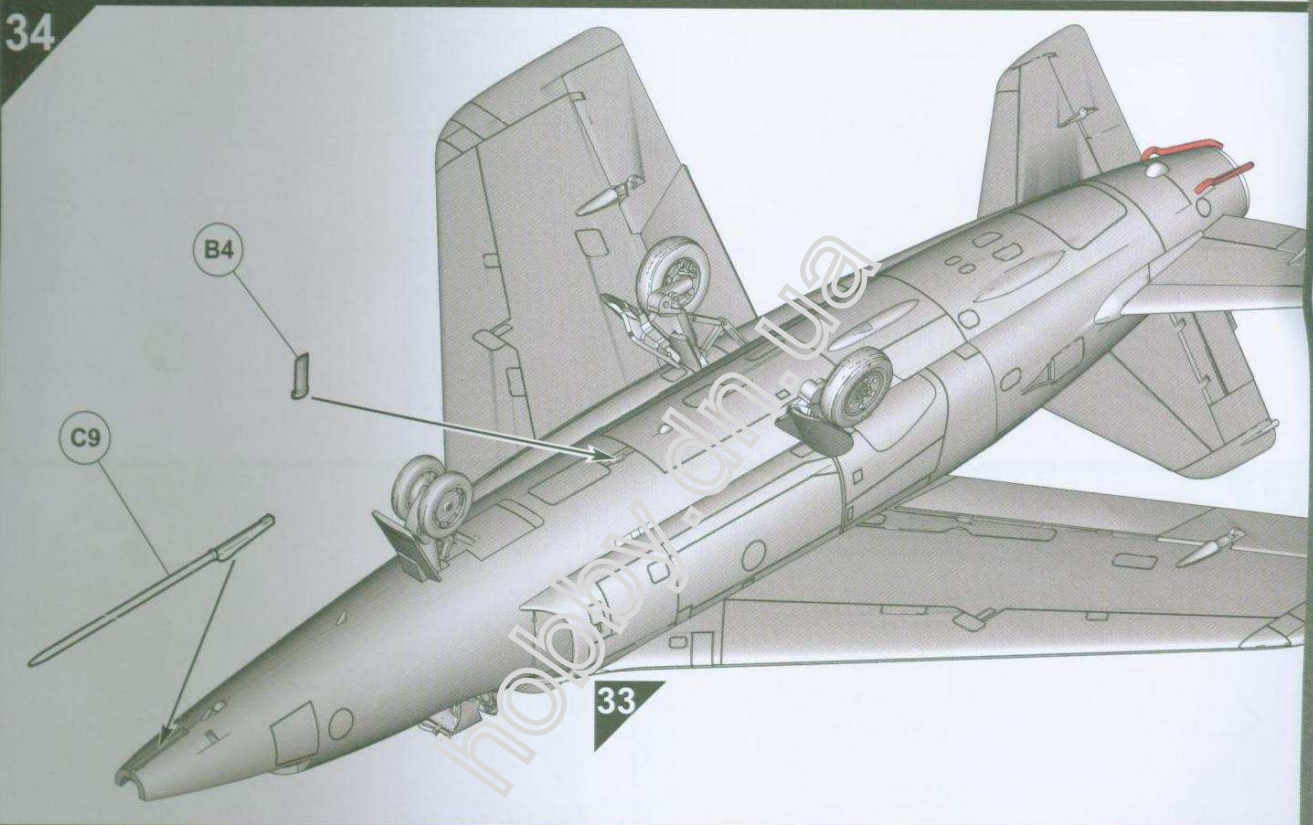

35

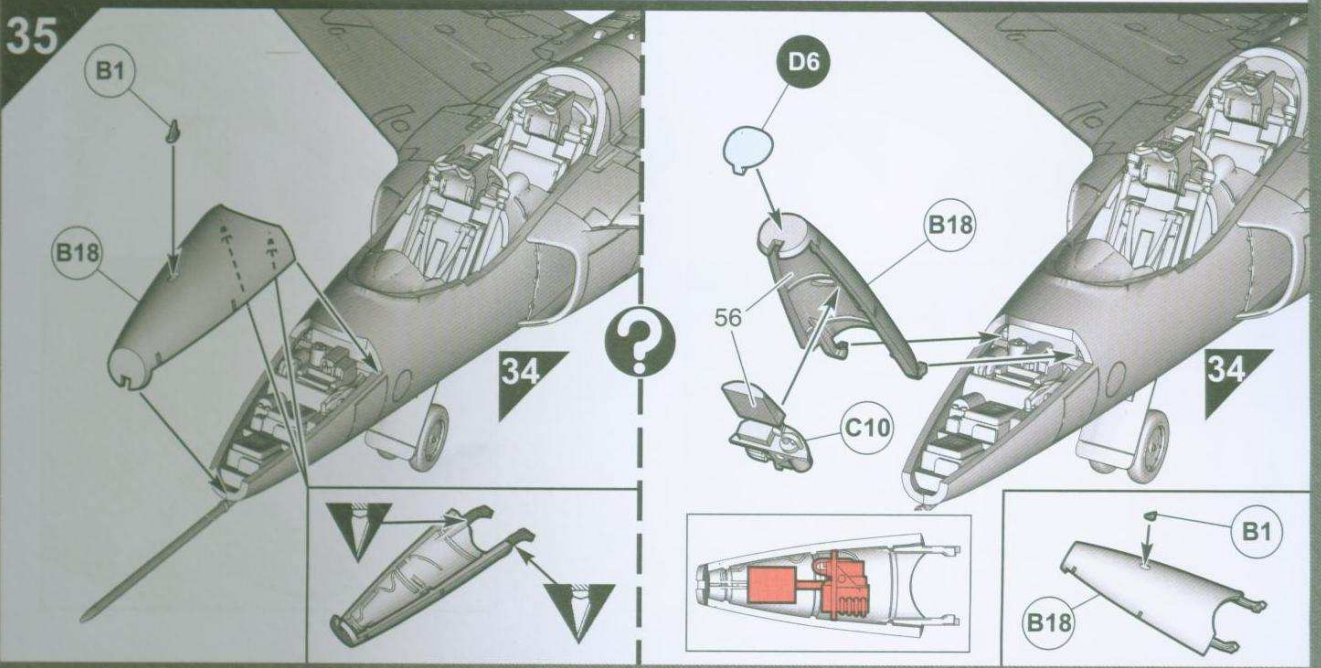

36

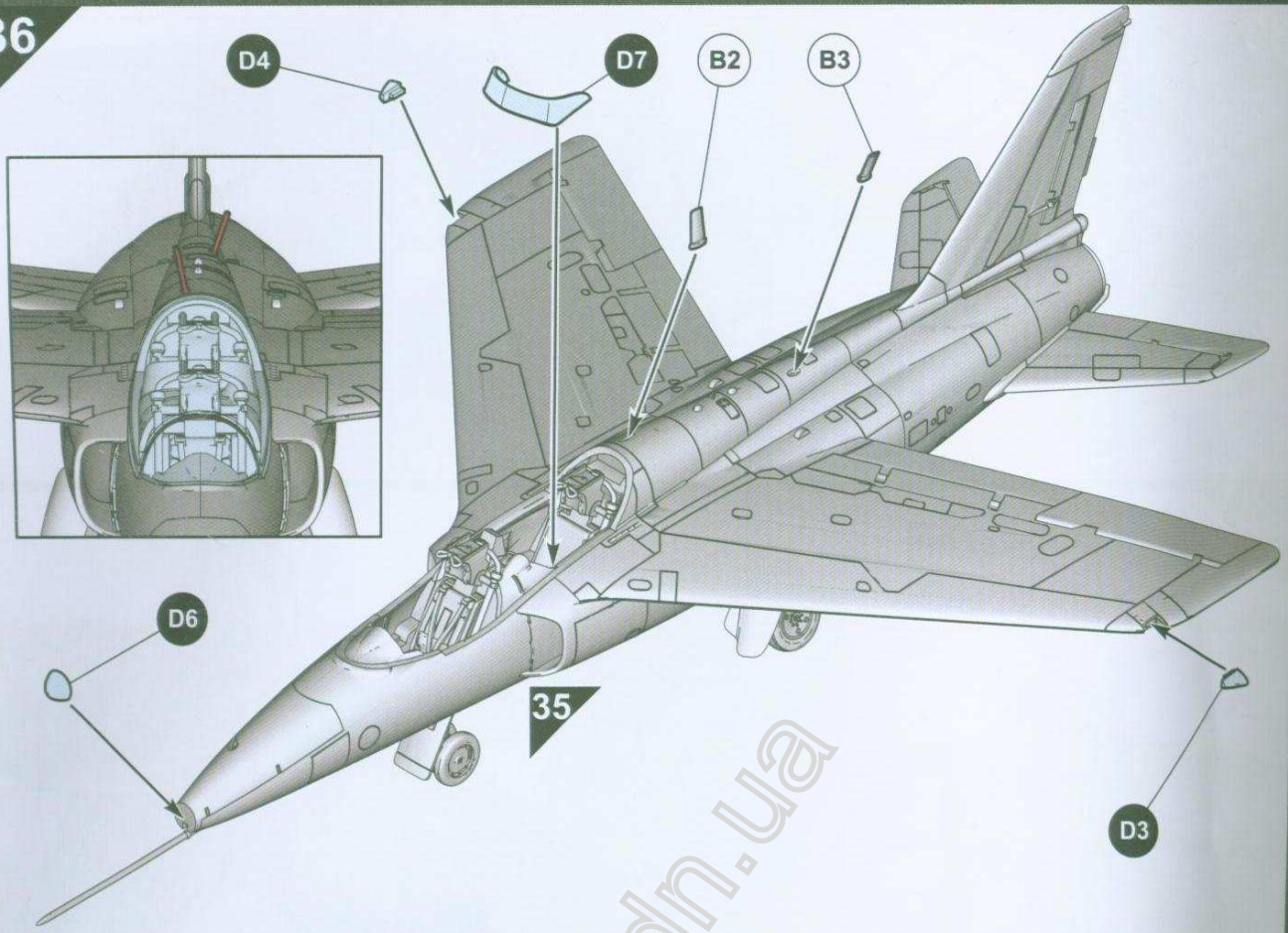

37

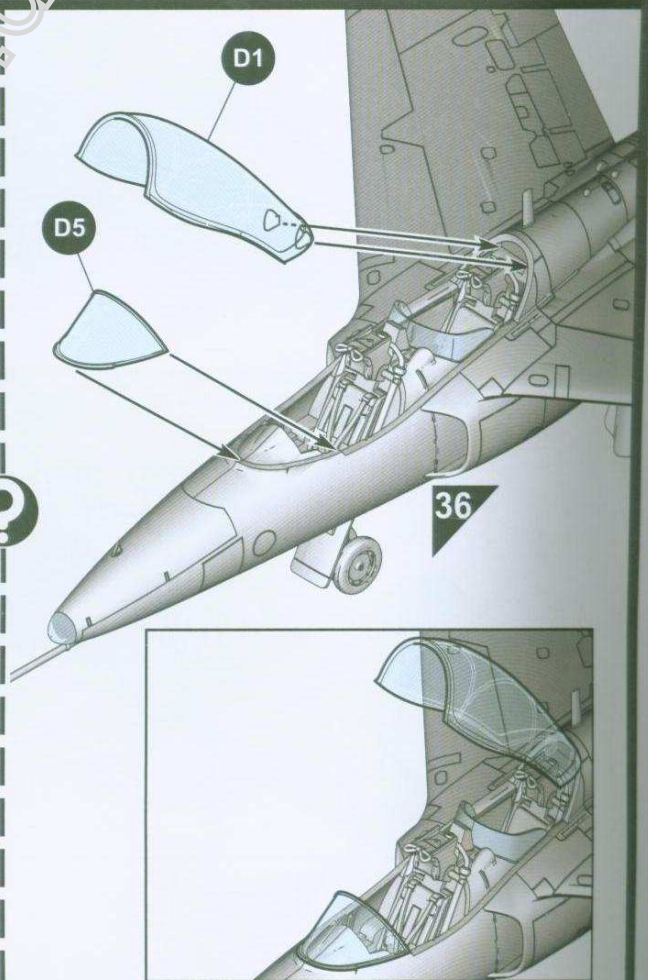
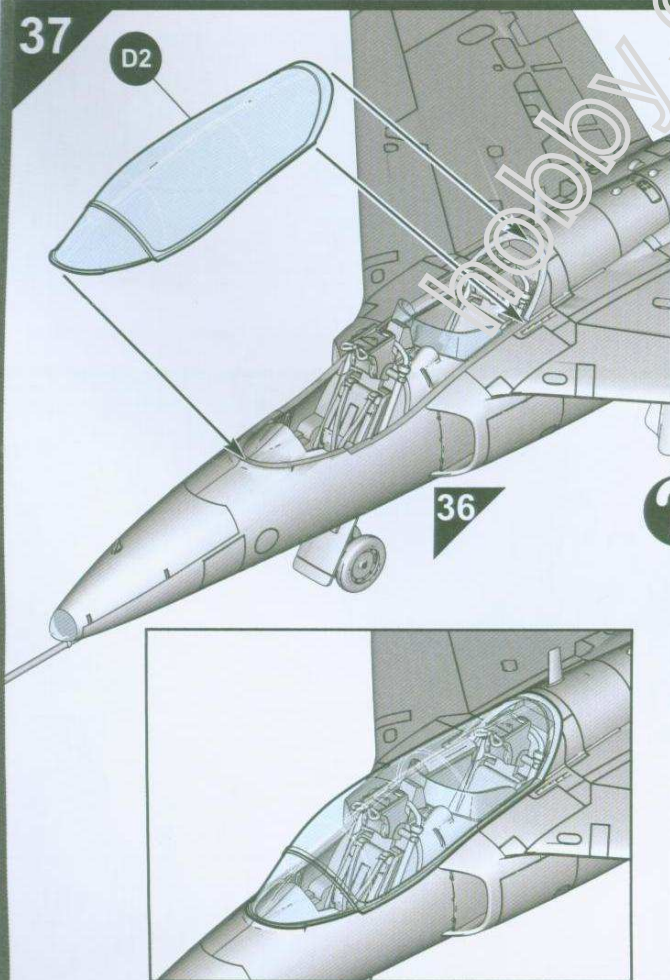

A Folland Gnat T.1
 The Red Arrows Aerobatic Team, Royal Air Force Kemble, Gloucestershire, England, 1977.



238
 Gloss Airframe Red
 Special Blue RAF/CAS

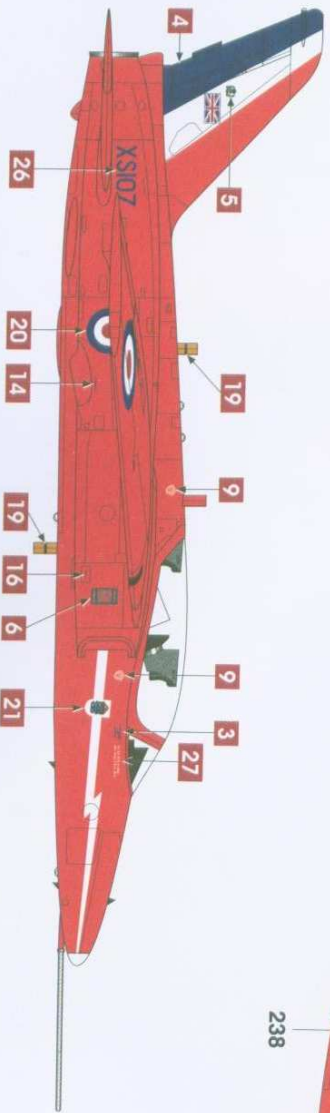
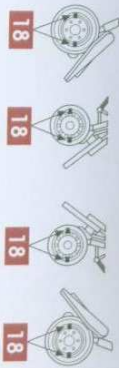
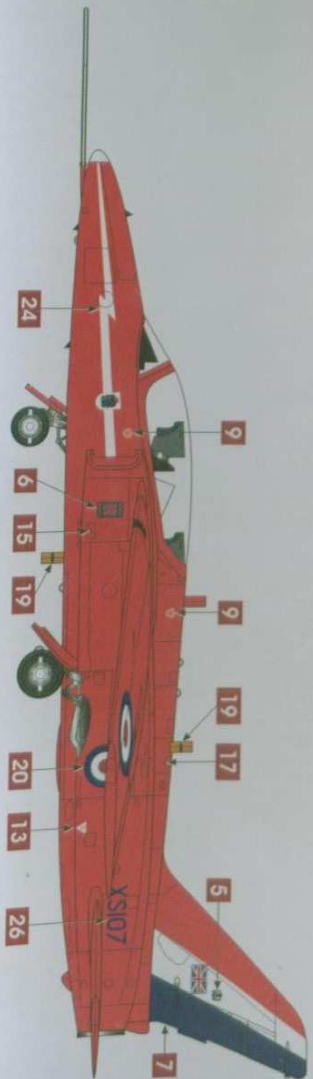
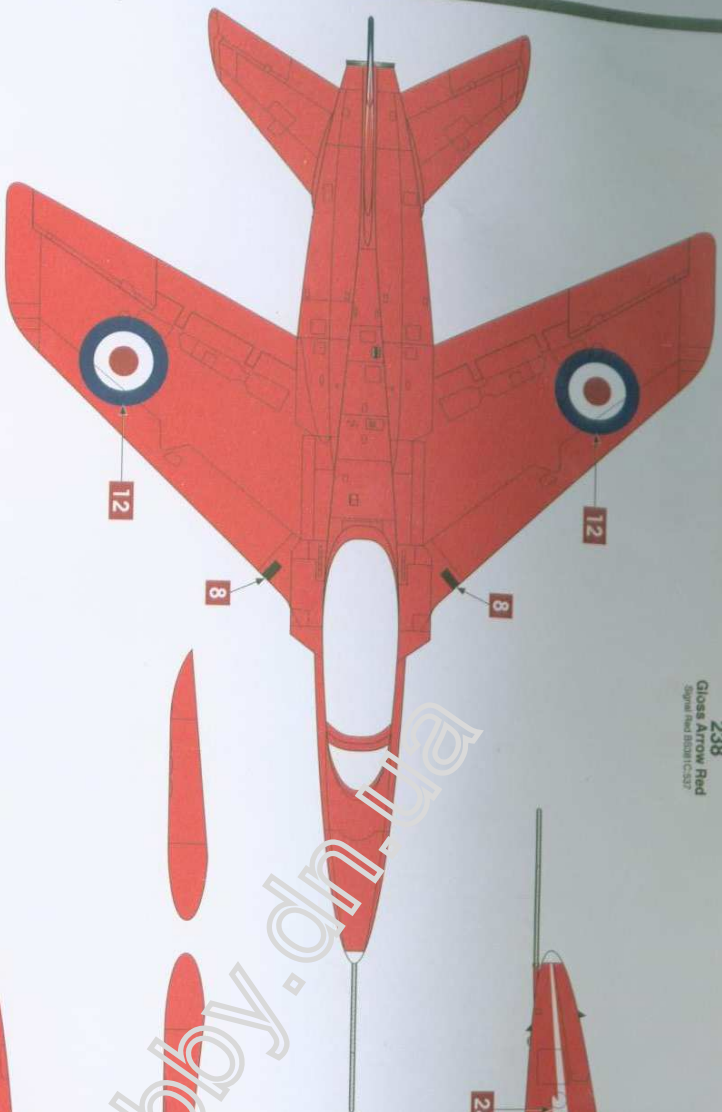

B Folland Gnat T.1
 The Red Arrows Aerobatic Team, Royal Air Force Kemble, Gloucestershire, England, 1979.

238
 Gloss Airframe Red
 Upper Surface CS37

