

B-52H U.S.

Stratofortress strategic Bomber



搜模閣

UA72200
1:72
SCALE

modelcollect

B-52H U.S. STRATOFORTRESS STRATEGIC BOMBER



"B-52" and "BUFF" redirect here. For other uses, see B-52 (disambiguation) and BUFF (disambiguation). The Boeing B-52 Stratofortress is an American long-range, subsonic, jet-powered strategic bomber. The B-52 was designed and built by Boeing, which has continued to provide support and upgrades. It has been operated by the United States Air Force (USAF) since the 1950s. The bomber is capable of carrying up to 70,000 pounds (32,000 kg) of weapons, and has a typical combat range of more than 8,800 miles (14,080 km) without aerial refueling.

Beginning with the successful contract bid in June 1946, the B-52 design evolved from a straight wing aircraft powered by six turboprop engines to the final prototype YB-52 with eight turbojet engines and swept wings. The B-52 took its maiden flight in April 1952. Built to carry nuclear weapons for Cold War-era deterrence missions, the B-52 Stratofortress replaced the Convair B-36. A veteran of several wars, the B-52 has dropped only conventional munitions in combat. The B-52's official name Stratofortress is rarely used; informally, the aircraft has become commonly referred to as the BUFF (Big Ugly Fat Fucker).

The B-52 has been in active service with the USAF since 1955. As of December 2015, 58 were in active service with 18 in reserve. The bombers flew under the Strategic Air Command (SAC) until it was disestablished in 1992 and its aircraft absorbed into the Air Combat Command (ACC); in 2010 all B-52 Stratofortresses were transferred from the ACC to the newly created Air Force Global Strike Command (AFGSC). Superior performance at high subsonic speeds and relatively low operating costs have kept the B-52 in service despite the advent of later, more advanced aircraft, including the canceled Mach 3 B-70 Valkyrie, the variable-geometry B-1 Lancer, and the stealth B-2 Spirit. The B-52 completed sixty years of continuous service with its original operator in 2015. After being upgraded between 2013 and 2015, it is expected to serve into the 2050s.

General characteristics

Crew: 5 (pilot, copilot, weapon systems officer, navigator, electronic warfare officer, and tail gunner until the removal of the tail gun in 1991)

Length: 159 ft 4 in (48.5 m)

Wingspan: 185 ft 0 in (56.4 m)

Height: 40 ft 8 in (12.4 m)

Wing area: 4,000 sq ft (370 m²)

Airfoil: NACA 63A219.3 mod root, NACA 65A209.5 tip

Empty weight: 185,000 lb (83,250 kg)

Loaded weight: 285,000 lb (120,000 kg)

Max. takeoff weight: 488,000 lb (220,000 kg)

Fuel capacity: 47,975 U.S. gal (39,948 imp gal; 181,810 L)

Zero-lift drag coefficient: 0.0119 (estimated)

Drag area: 47.80 sq ft (4.42 m²)

Aspect ratio: 8.56

Powerplant: 8 × Pratt & Whitney TF33-P-3/103 turbofans, 17,000 lbf (76 kN) each

Performance

Maximum speed: 560 kn (650 mph, 1,047 km/h)

Cruise speed: 442 kn (525 mph, 844 km/h)

Combat radius: 4,480 mi (3,890 nmi, 7,210 km)

Ferry range: 10,145 mi (8,764 nmi, 16,232 km)

Service ceiling: 50,000 ft (15,000 m)

Rate of climb: 6,270 ft/min (31.85 m/s)

Wing loading: 120 lb/ft² (586 kg/m²)

Thrust/weight: 0.31

Lift-to-drag ratio: 21.5 (estimated)

Armament

Guns: 1 × 20 mm (0.787 in) M61 Vulcan cannon originally mounted in a remote controlled tail turret on the H-model, removed from all current operational aircraft in 1991

Bombs: Approximately 70,000 lb (31,500 kg) of fixed ordnance; bombs, mines, missiles, in various configurations.

Avionics

Electro-optical viewing system that uses platinum selenide forward looking infrared and high resolution low-light-level television sensors

ADR-8 chaff rocket (1965–1970)

LITENING Advanced Targeting System

Sniper Advanced Targeting Pod

IBM AP-101 computer

●READ BEFORE ASSEMBLY

1. When you use glue or paint, do not near flame, and use in a well-ventilated room.
2. Take extra care in handling photo etch parts in order to avoid injury
3. When you take parts off the runner frame, use modeling scissors and trim excess plastic with a cutter or a file.
4. Glue and paint are not included.
5. This product is only suitable for experienced more than 14 years old.

●装配之前仔细阅读:

1. 勿於近火处使用胶水或油漆, 并打开窗户保持空气流通。
2. 取蚀刻片时应特别注意安全, 防止利边划伤手指。
3. 从胶架中取出部件时, 应用模型专用剪, 并用界刀或小锉除去多余的胶料。
4. 请使用塑料胶水和油漆, 模型内不含。
5. 本产品不适合14岁以下没有经验的模型爱好者。

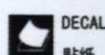
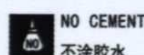
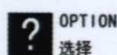
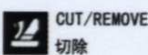
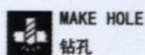
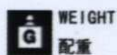
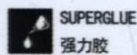

DECAL APPLICATION

1. Cut off decal from sheet.
2. Dip the decal in tepid water 40° C for about 10 sec. and place on a clean cloth.
3. Hold the backing sheet edge and slide decal onto the model.
4. Move decal into position by wetting decal with finger.
5. Press decal gently down with a soft cloth until excess water and air bubbles are gone.

水贴纸的使用:

1. 从水贴上剪下印花。
2. 将印花放入温水中浸10秒, 然后放在干净布上。
3. 拿着印花纸板将印花移到模型上。
4. 手指蘸水将印花移到适当的位置。
5. 用软布轻压印花直至不干, 气泡消失。

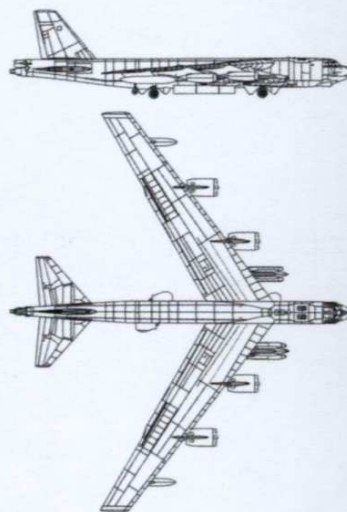

Parts

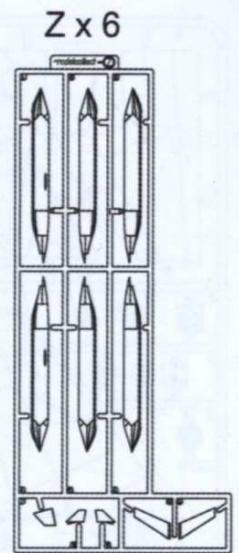
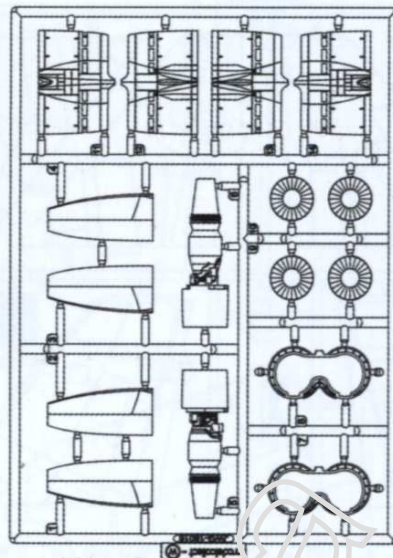
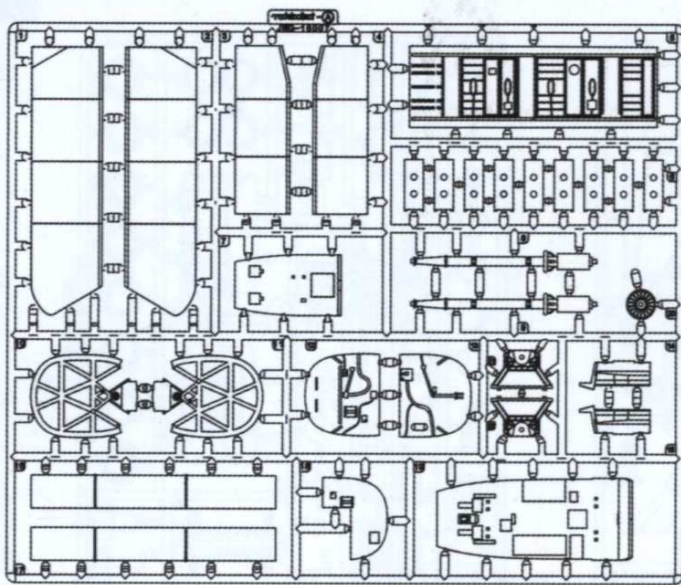

W x 2

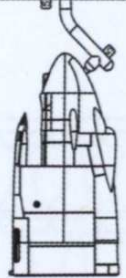
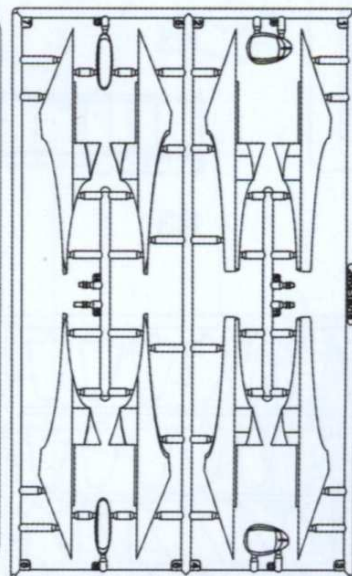
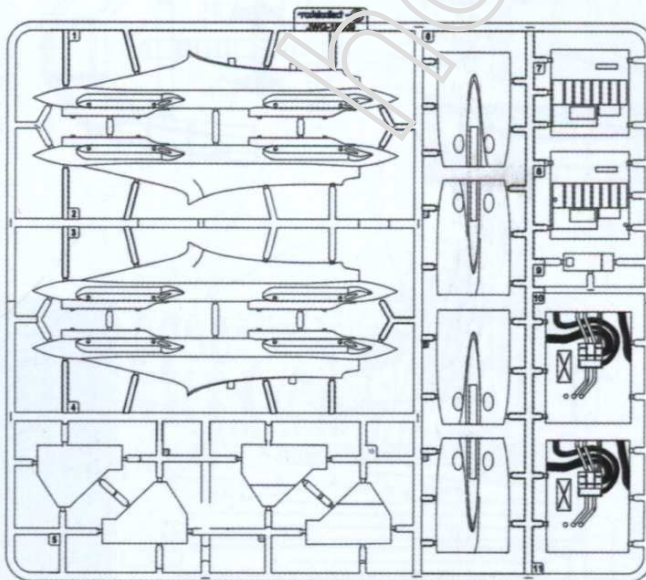
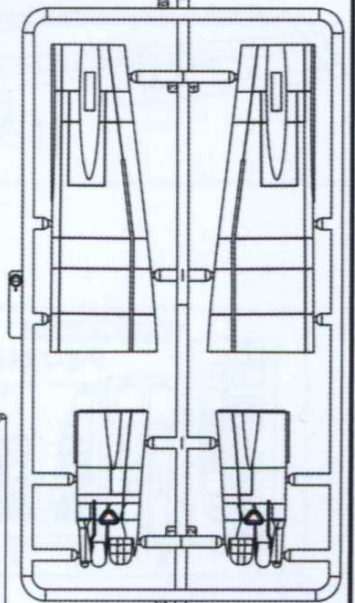
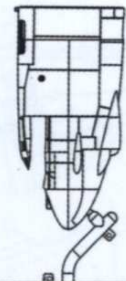
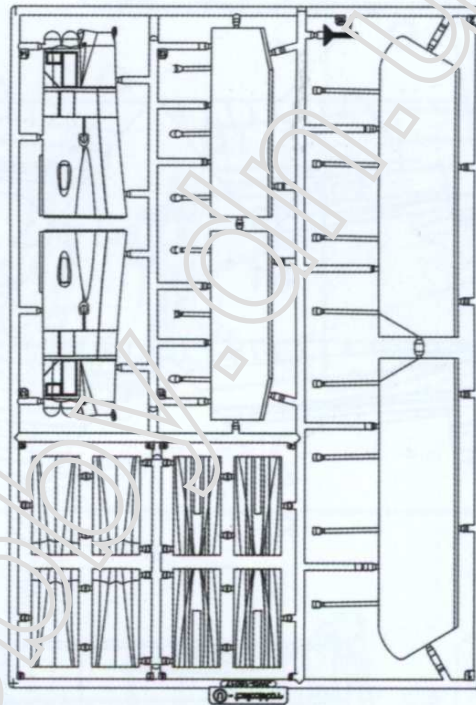
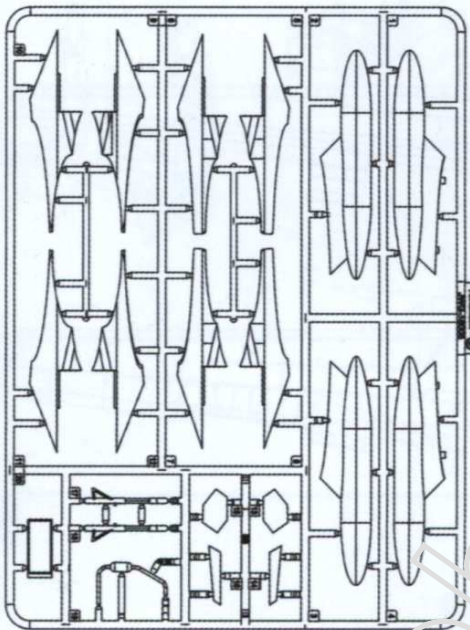

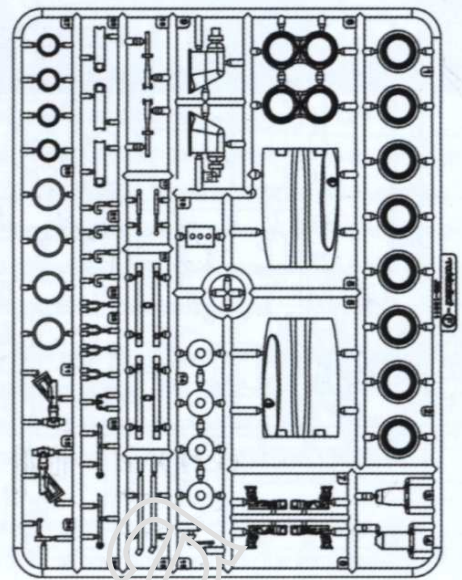
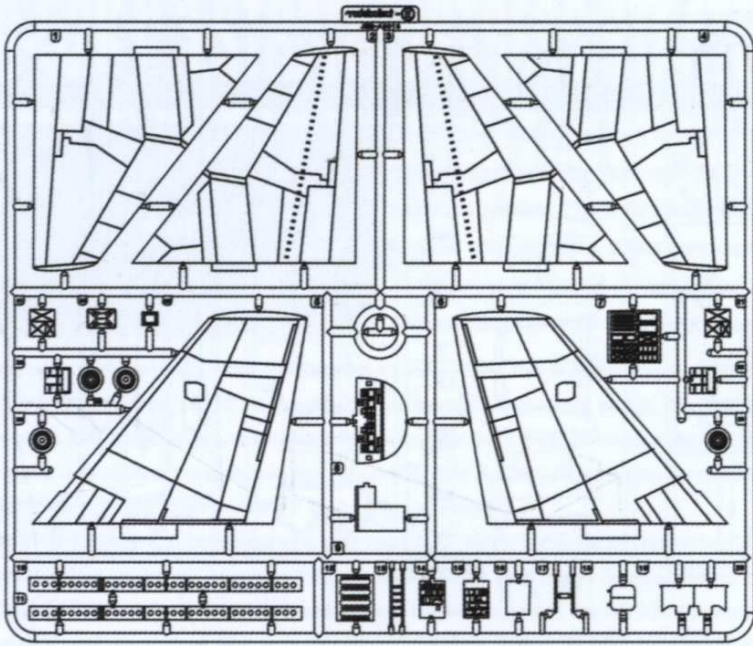

x 2

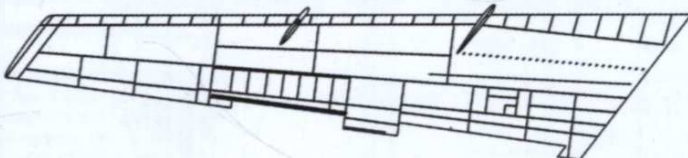

N1

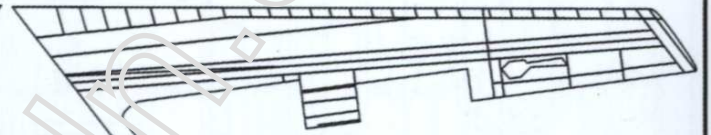

N2

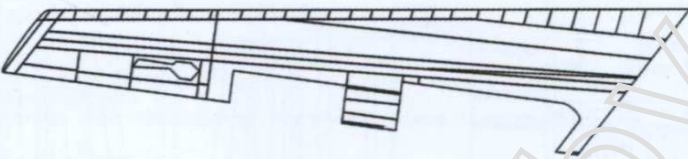

R1

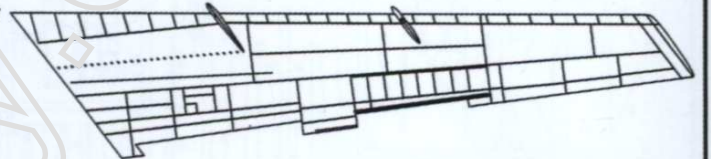

R2

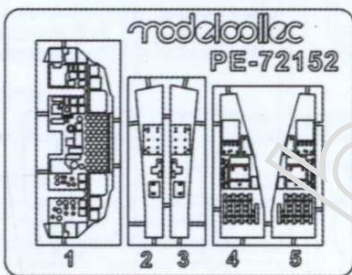

N3

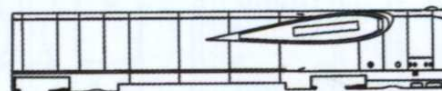

R3

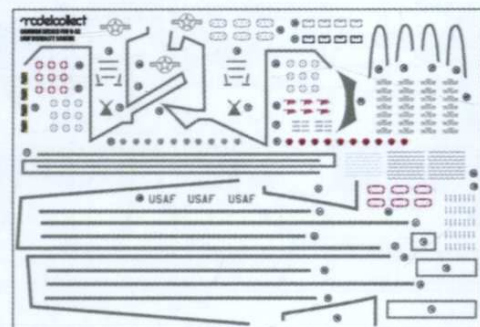
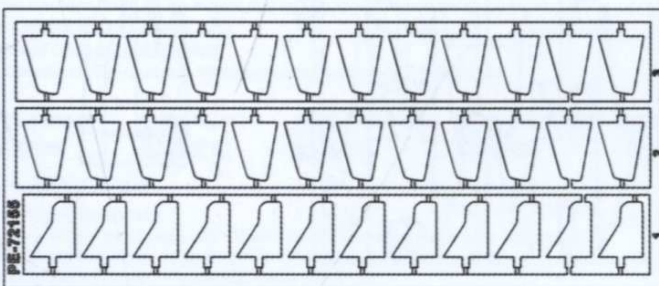
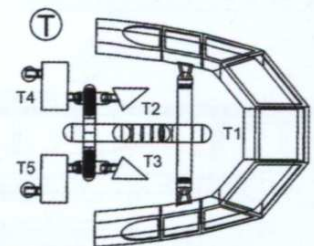

rodcoolk
BD
BD
029
029
AFRC AFRC

1

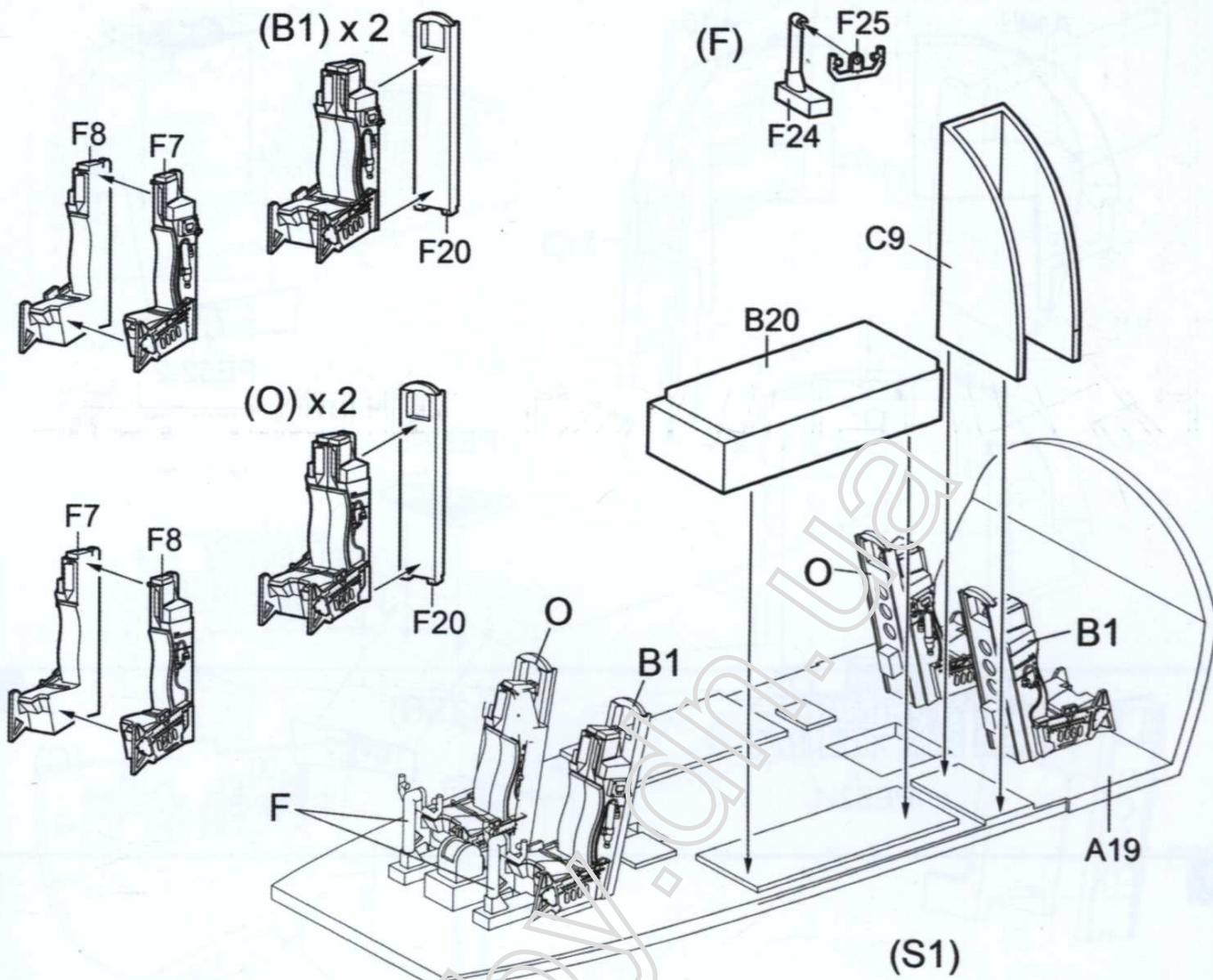

2

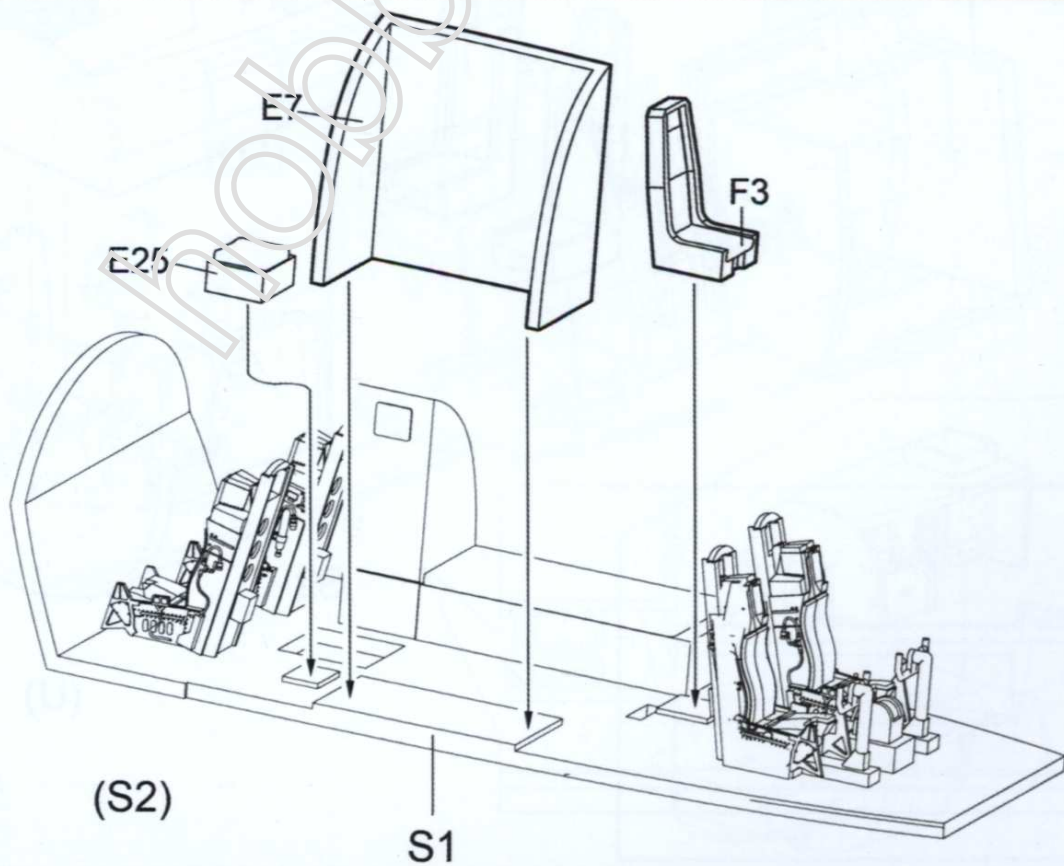

3

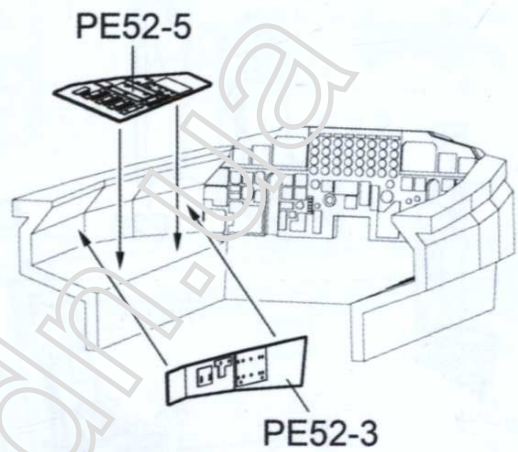
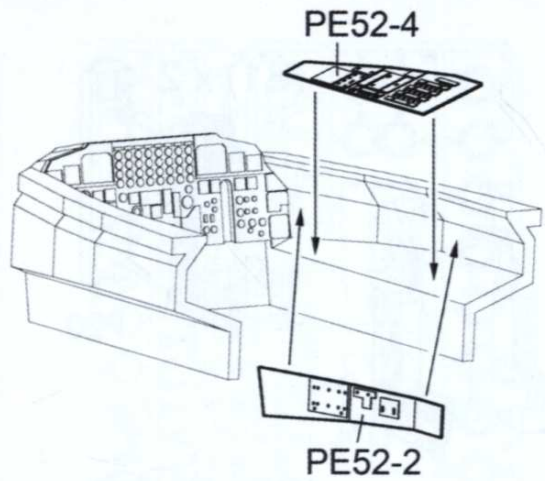
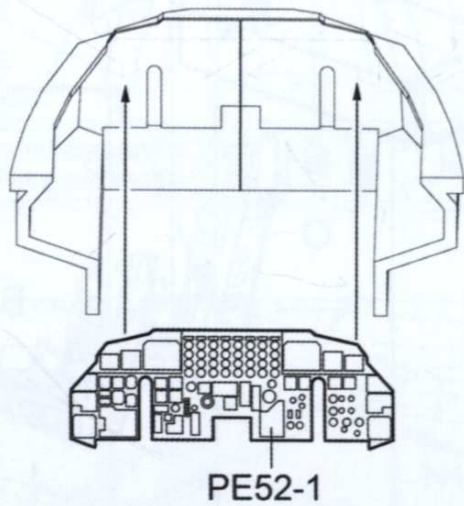
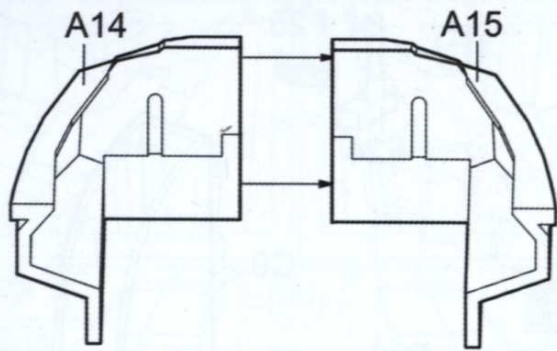

(C)

4

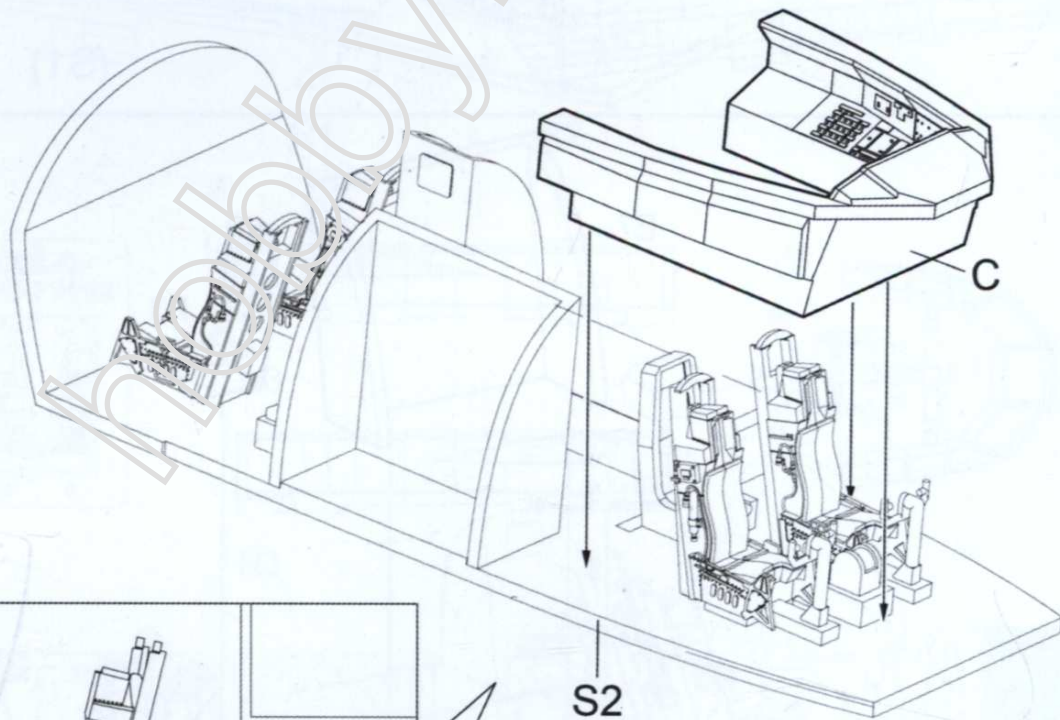

(U)

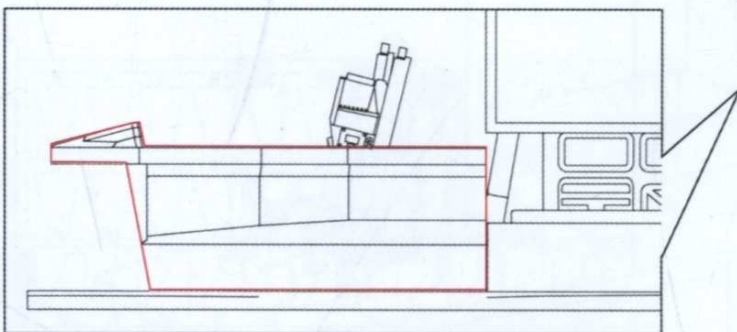

5

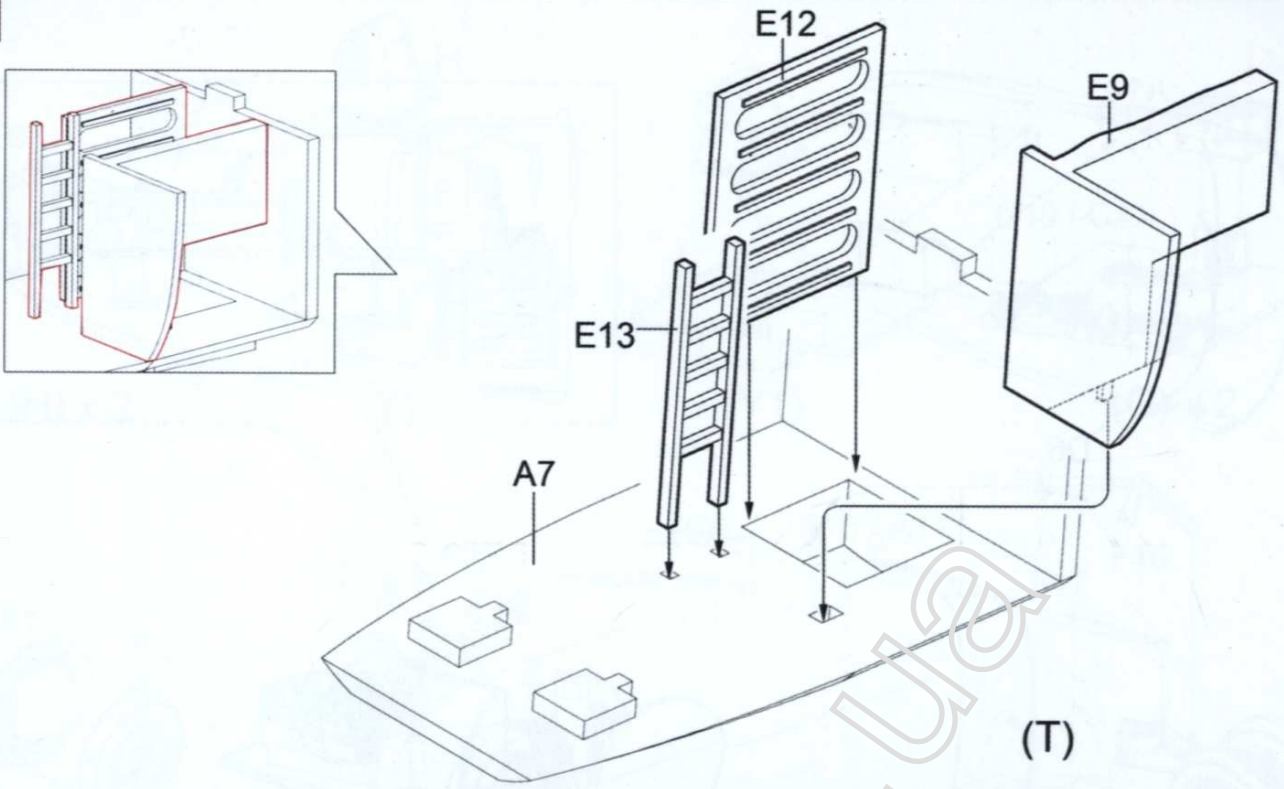

6

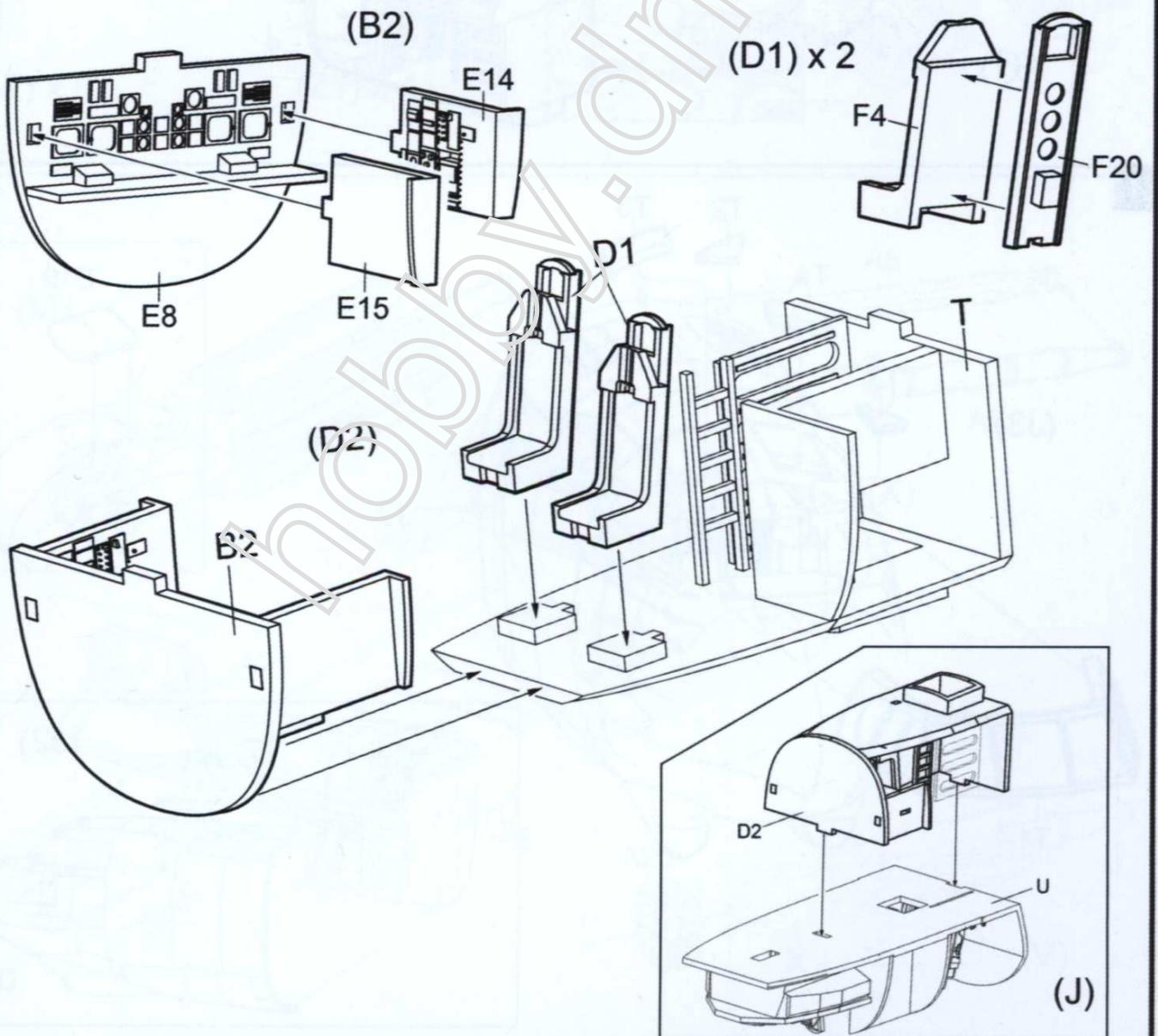

7

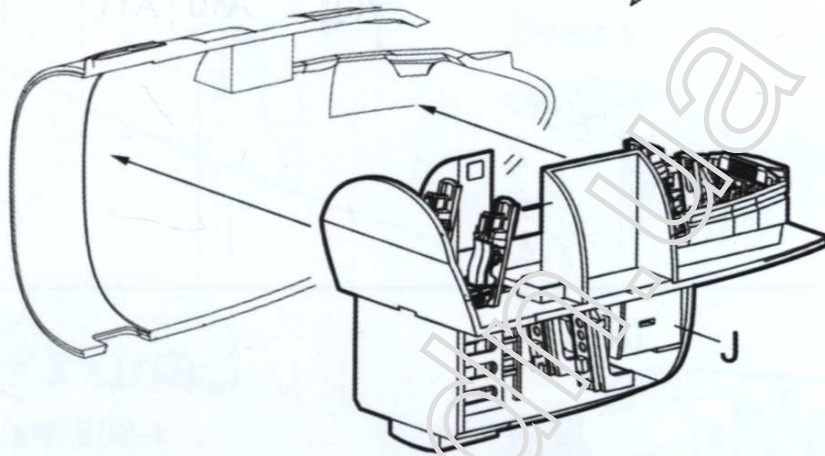
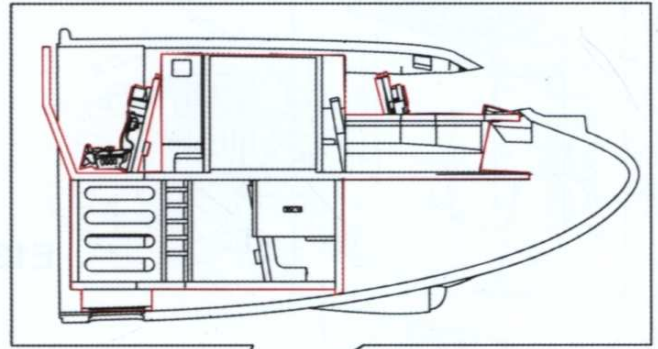
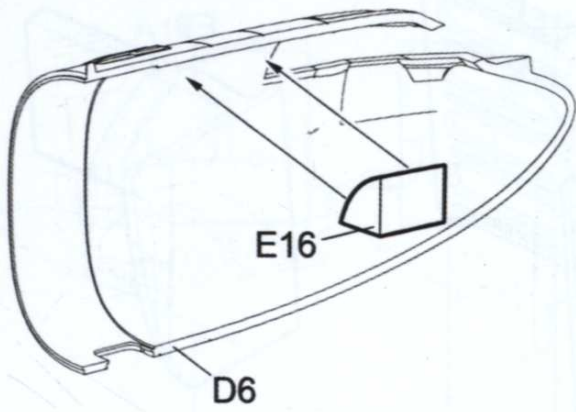

(J1)

8

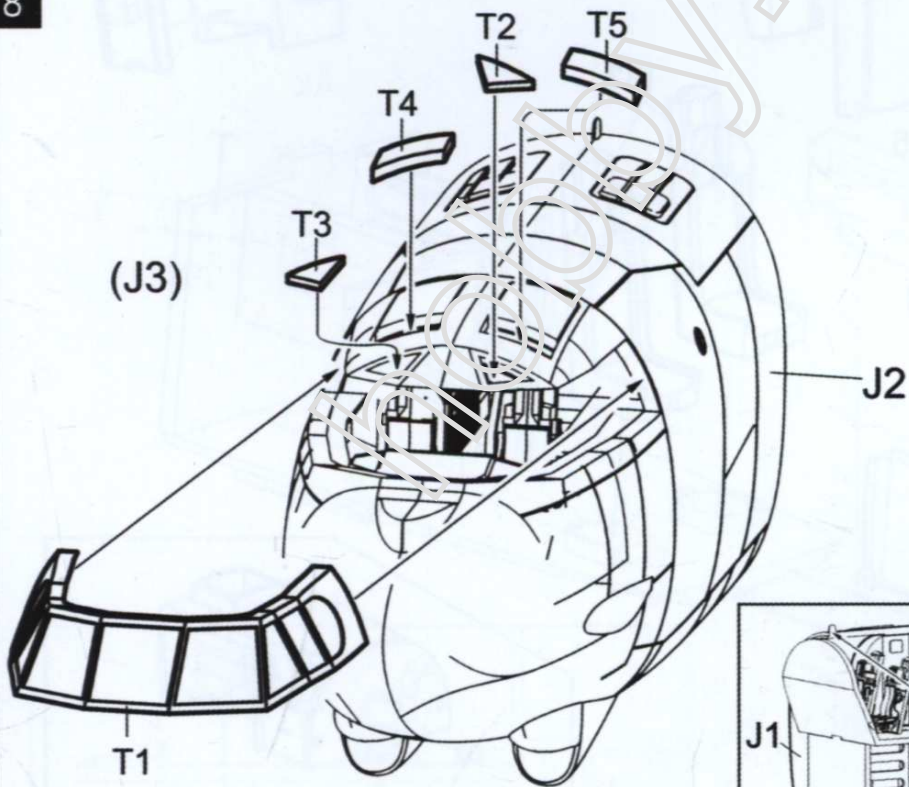

(J3)

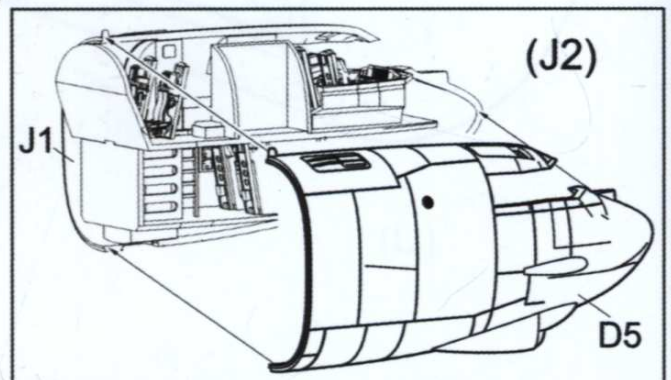

(J2)

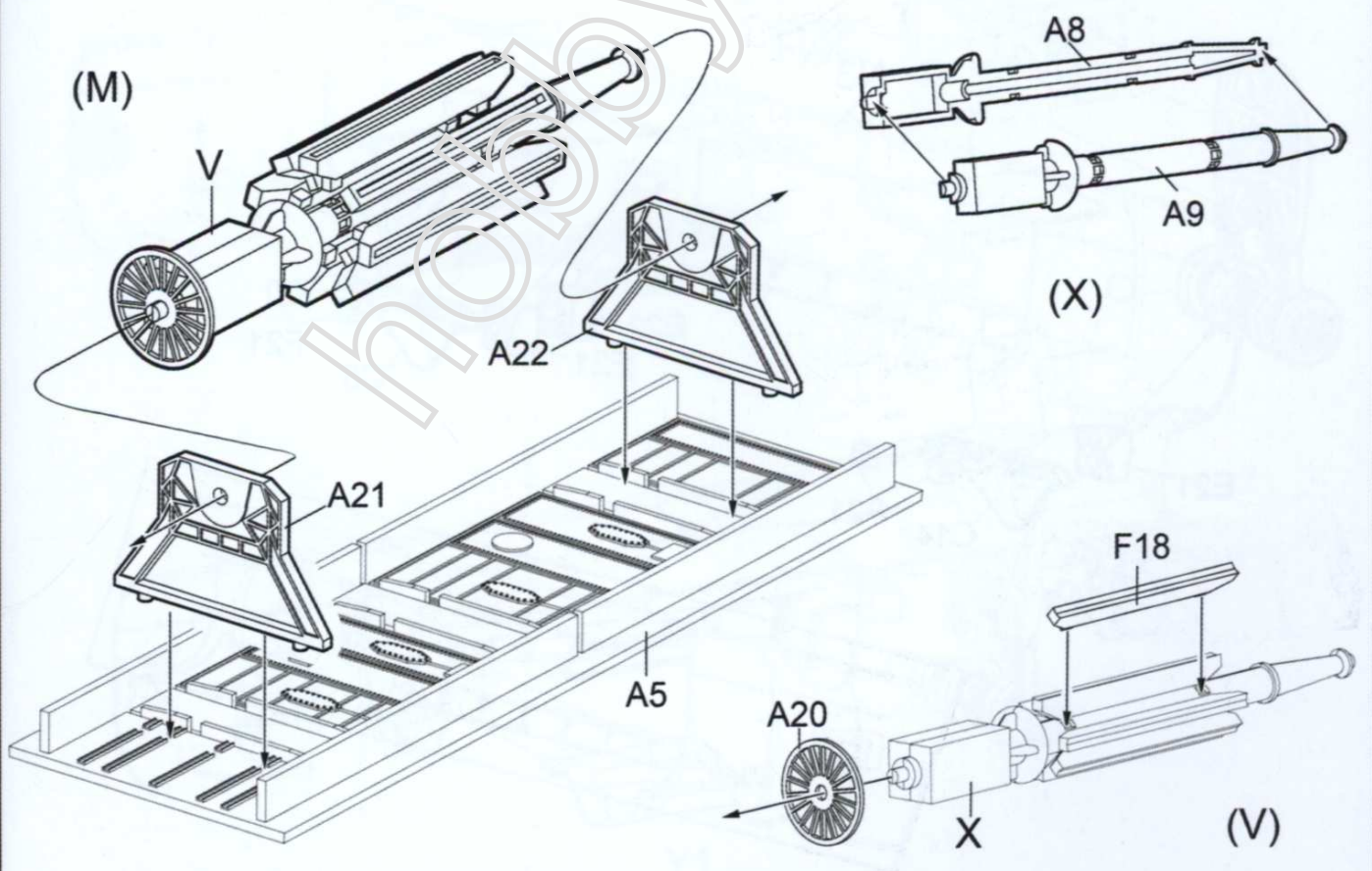
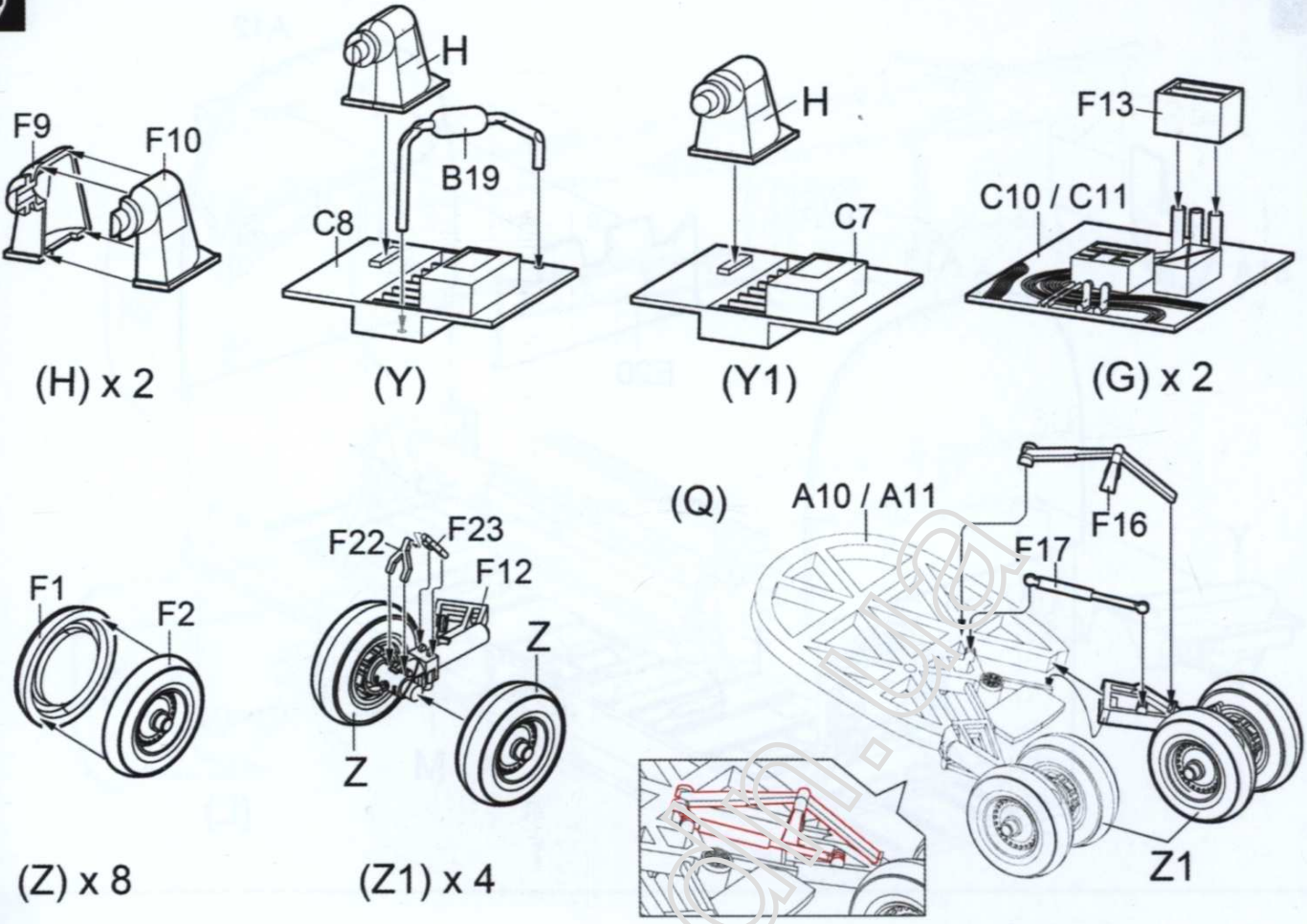

11

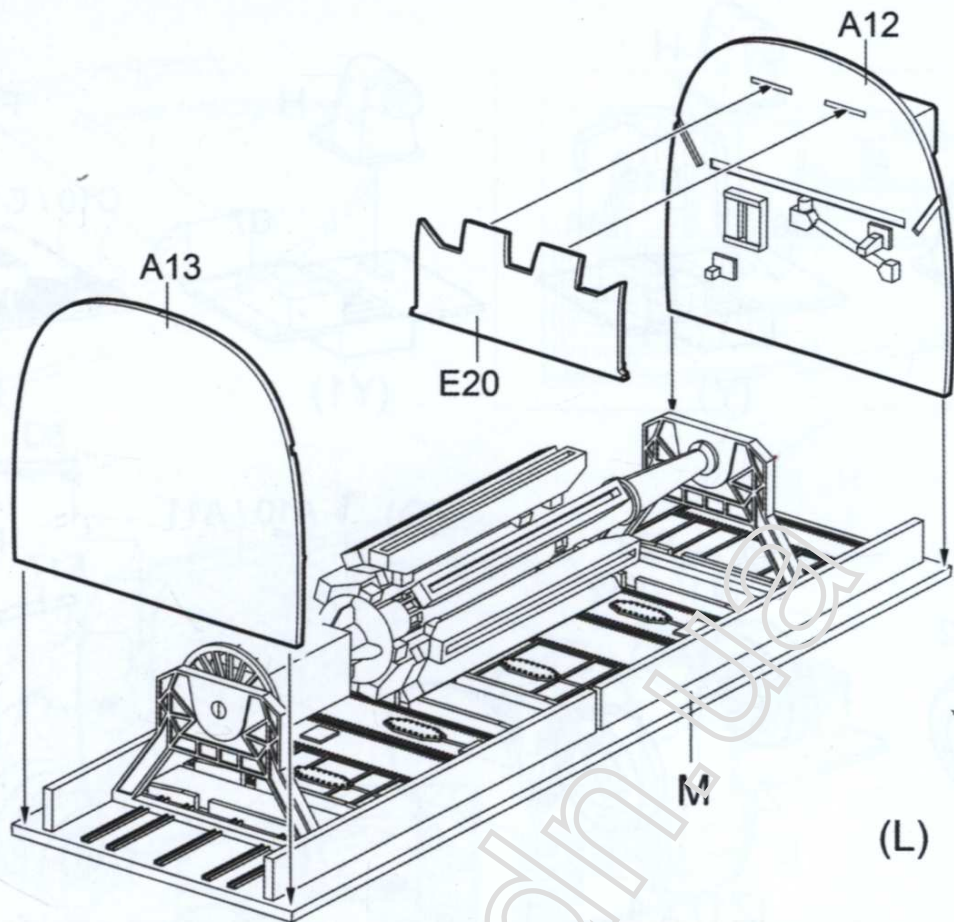

12

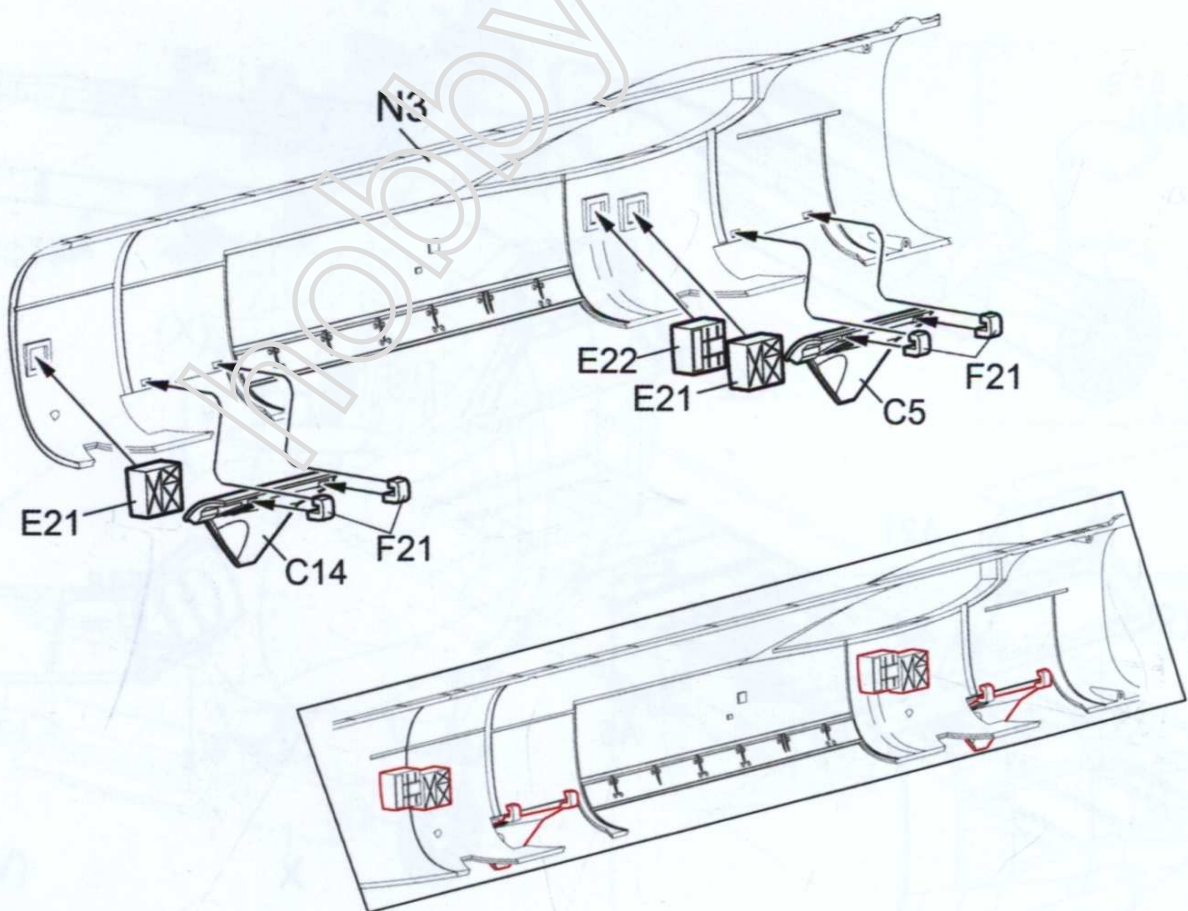

13

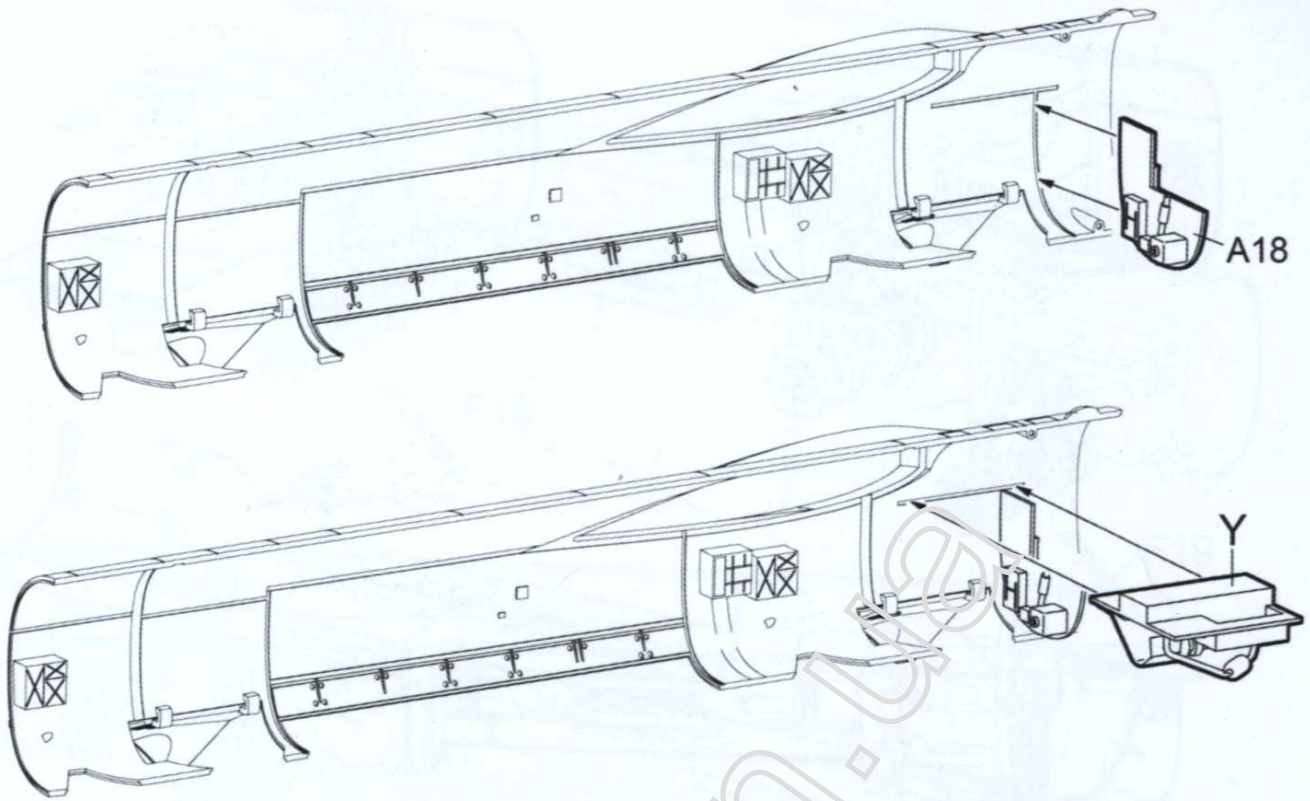

14

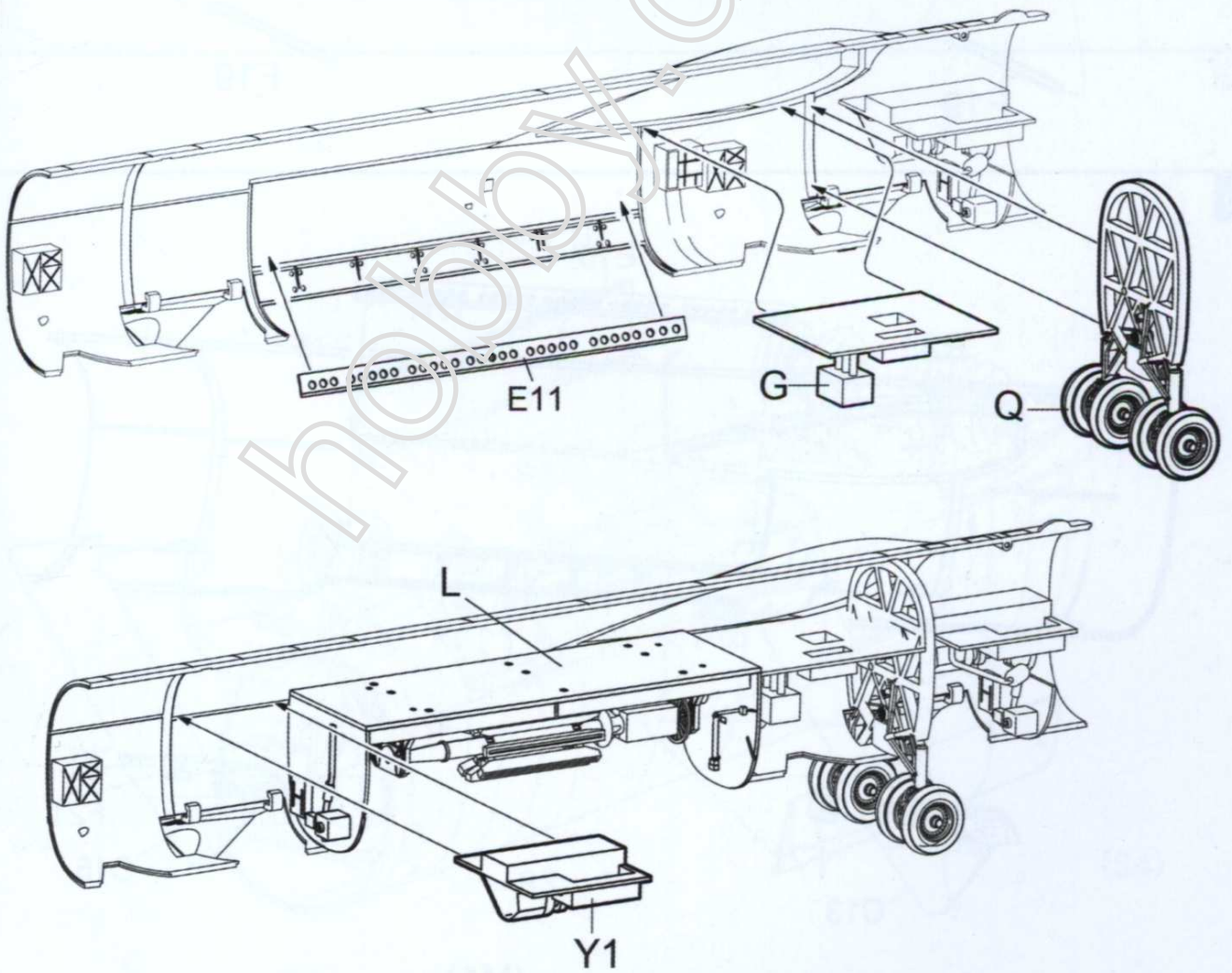

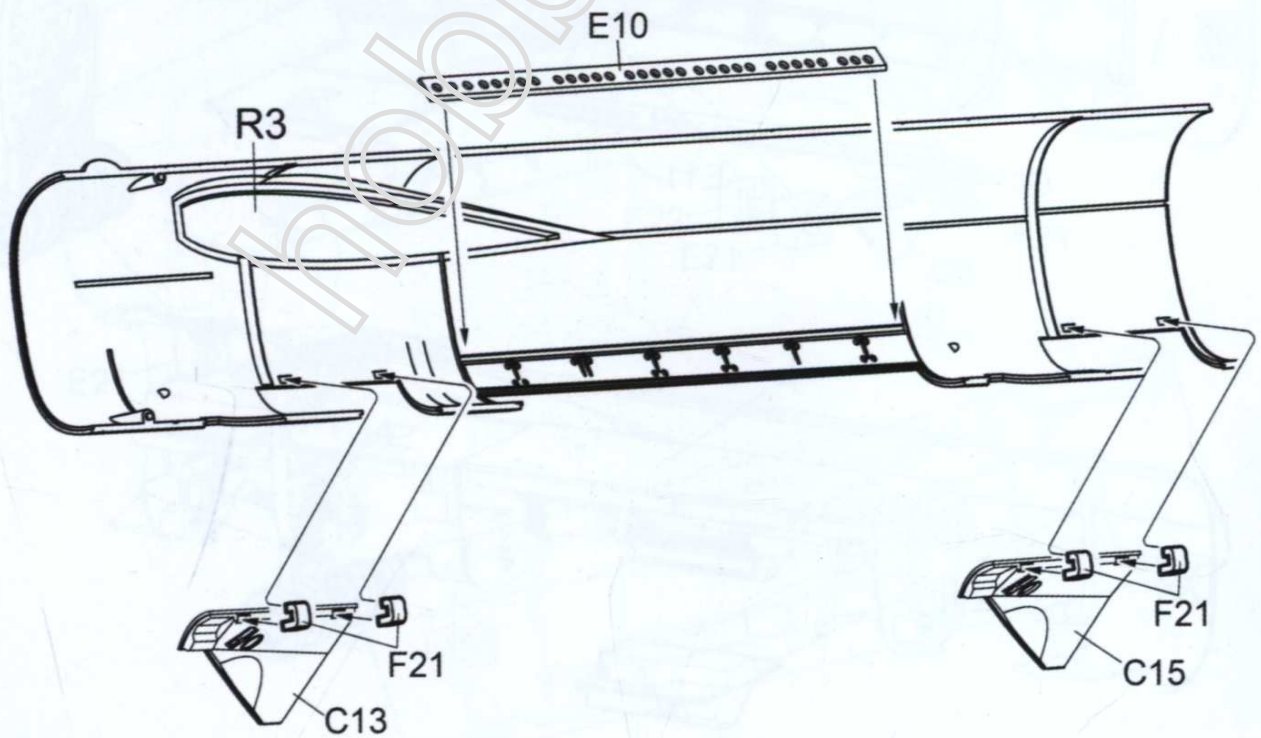
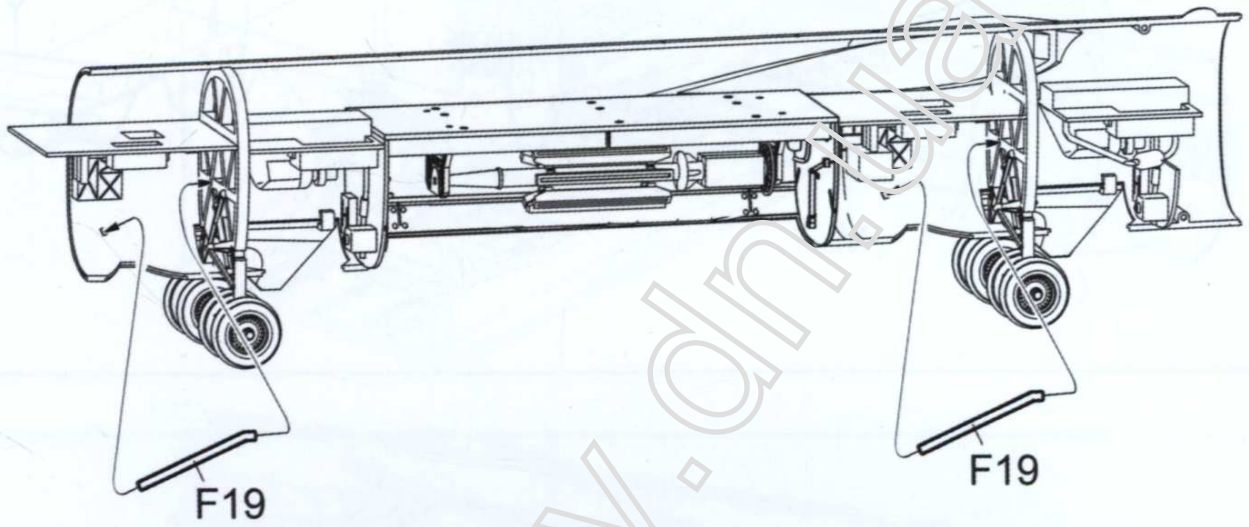
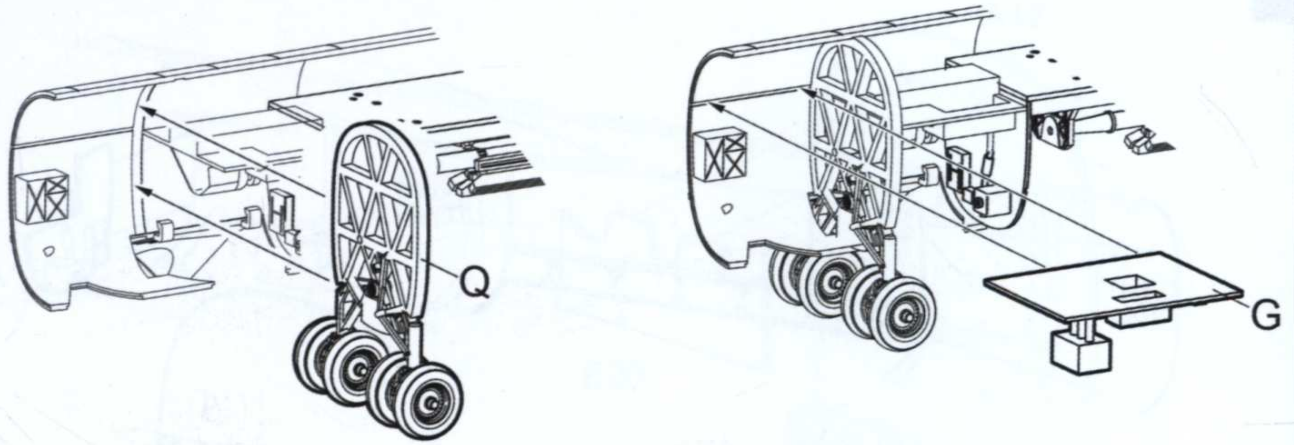

(M1)

17

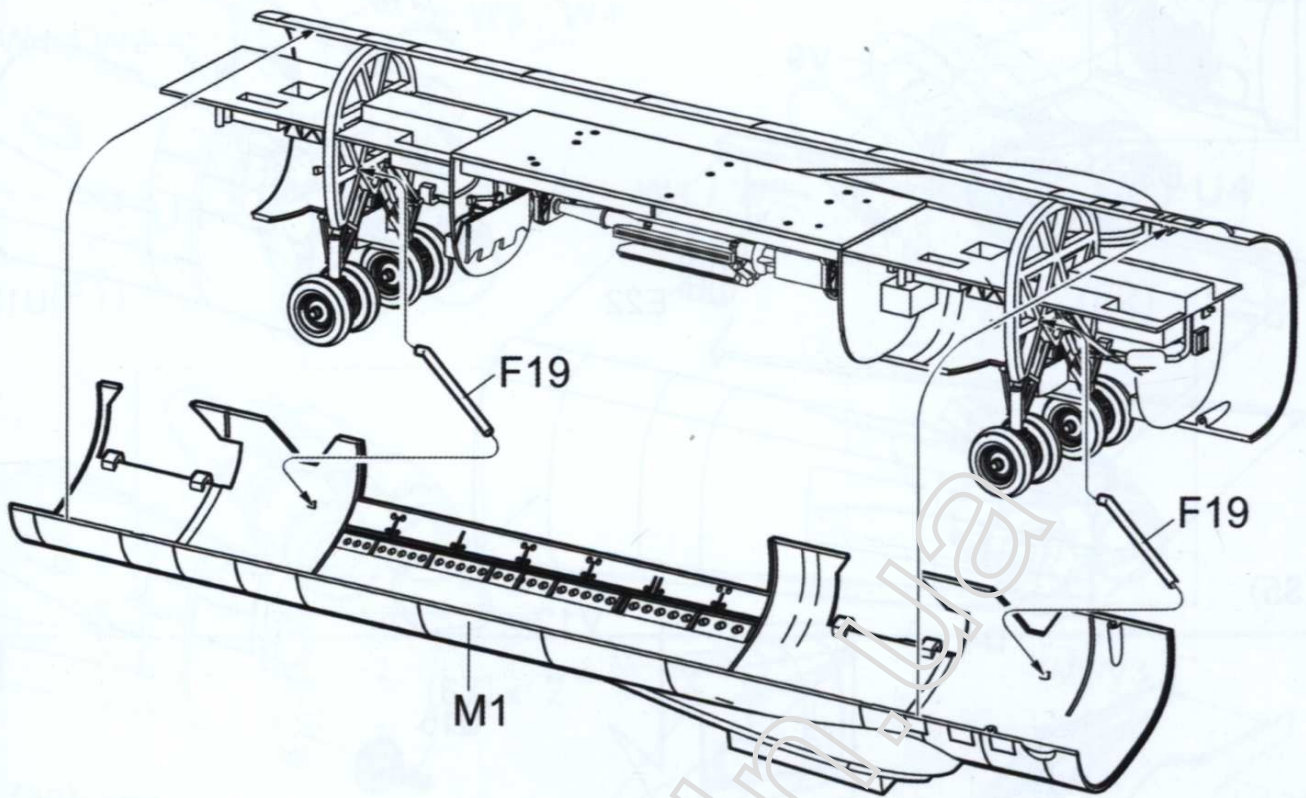

(S3)

18

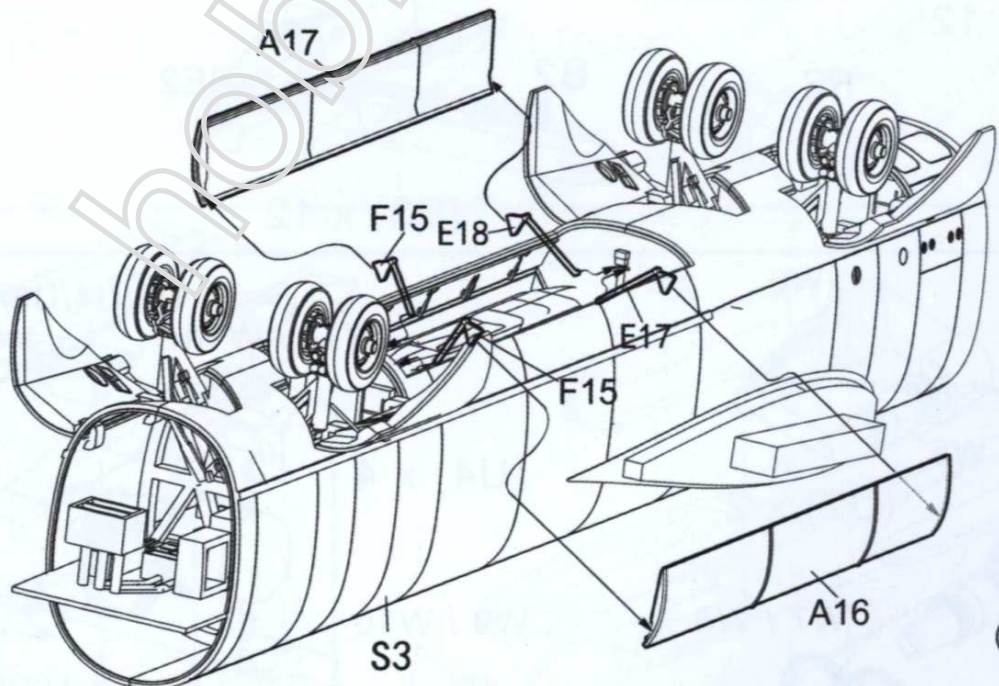

(S4)

19

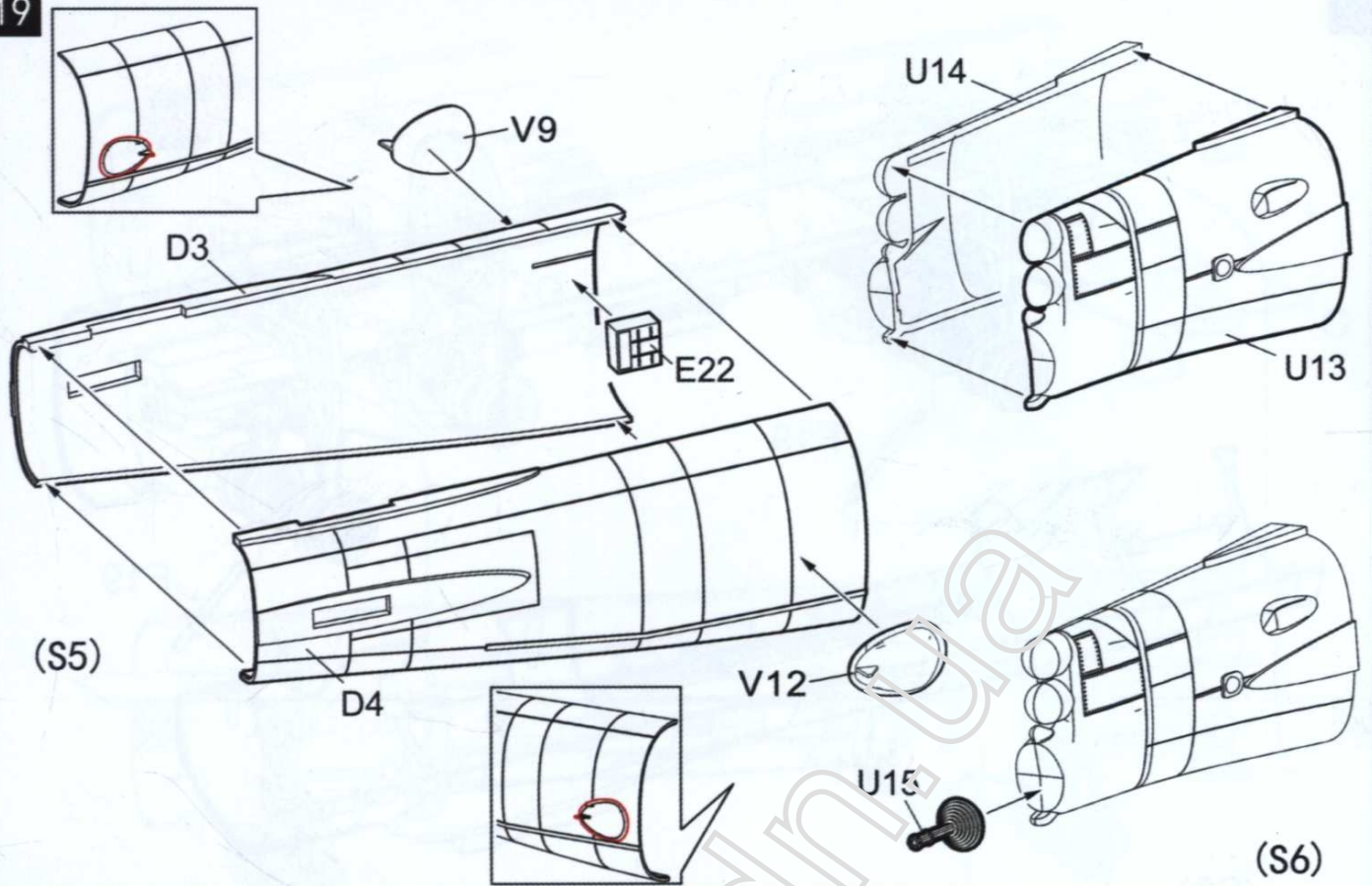

20

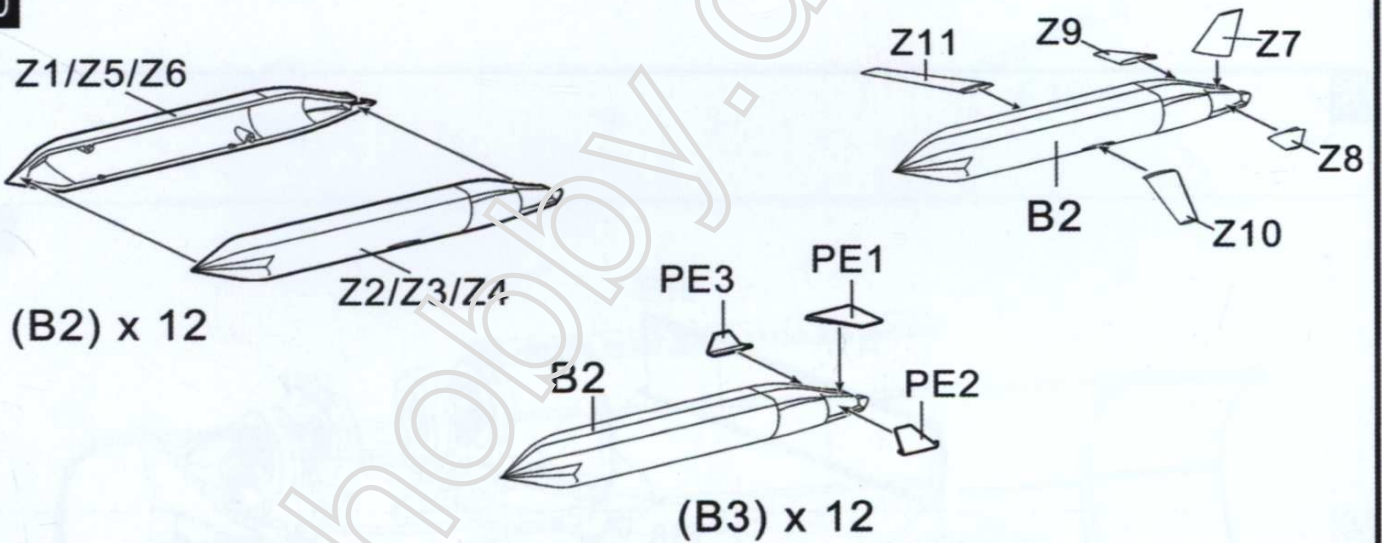

21

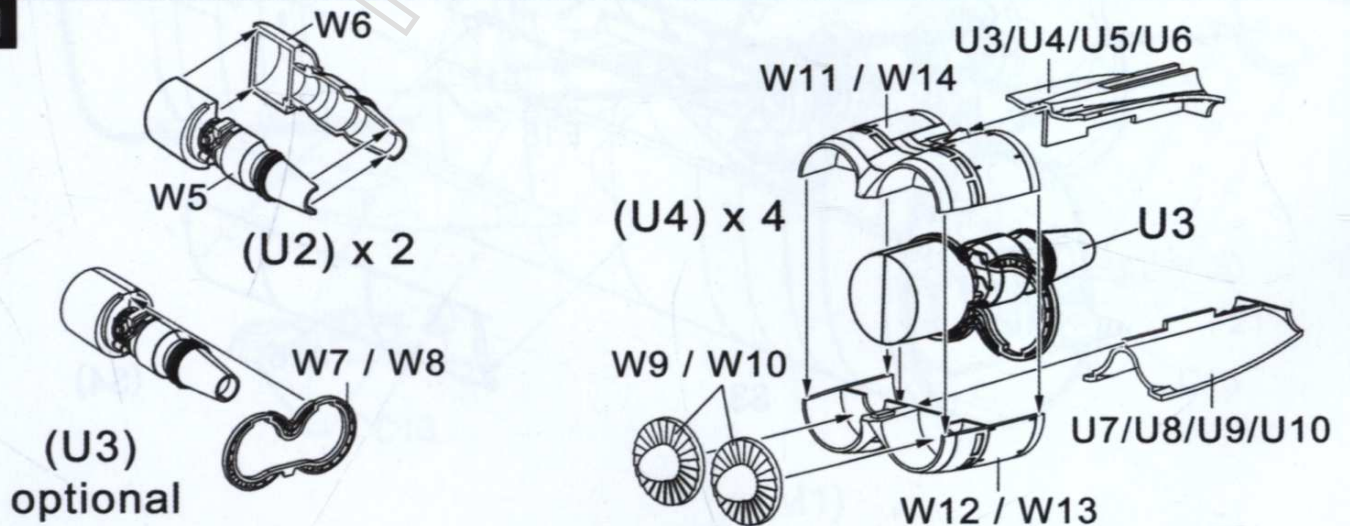

22

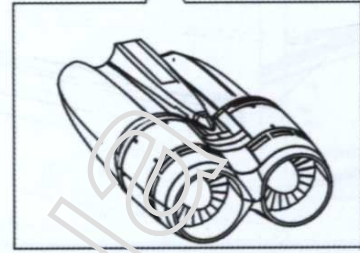
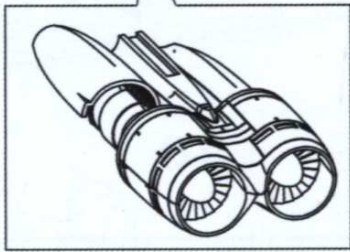
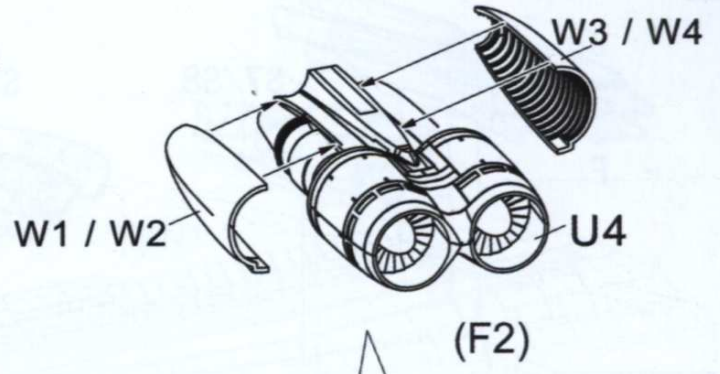
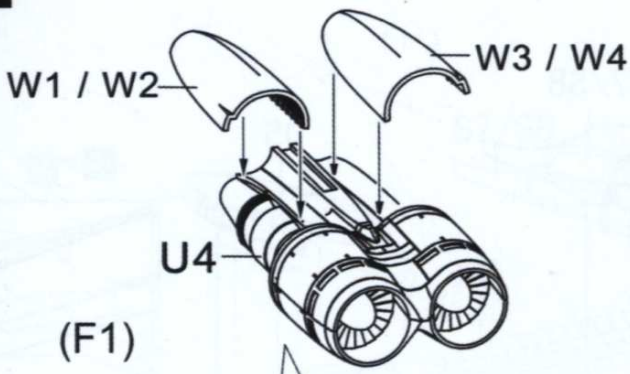

23

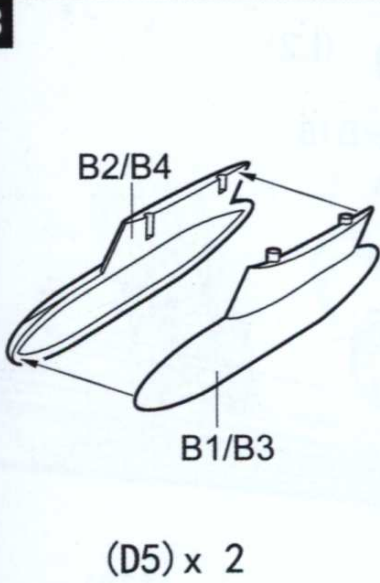

(S7) x 2

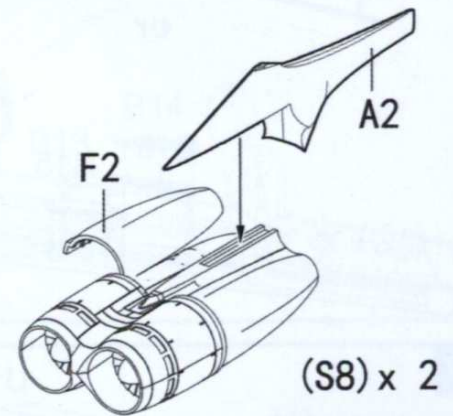
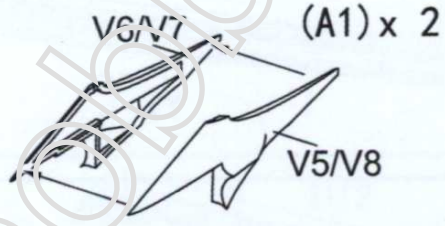
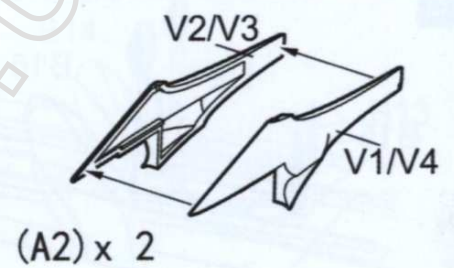
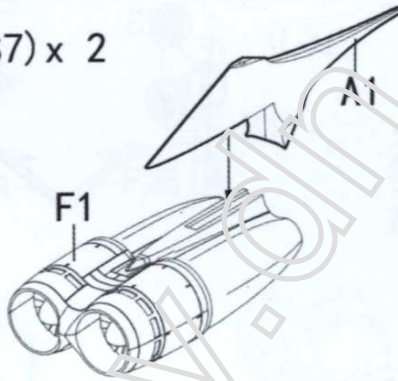

24

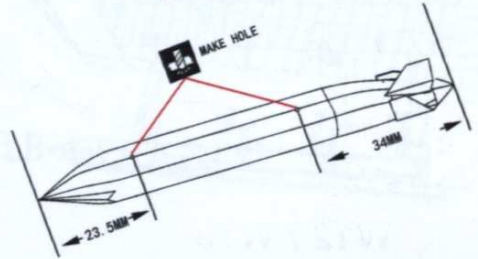
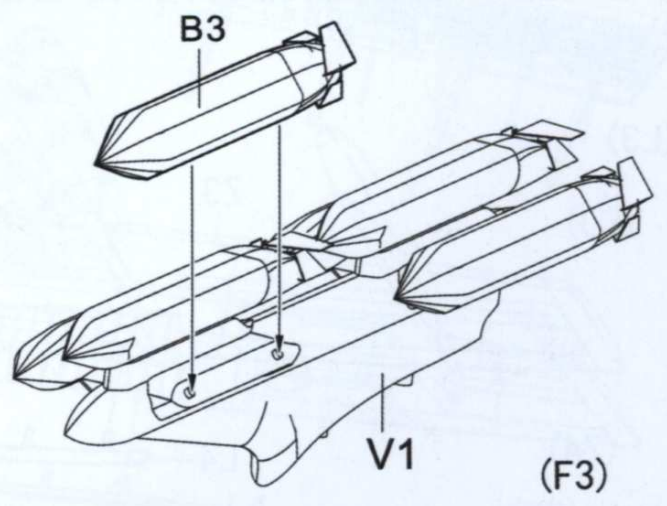
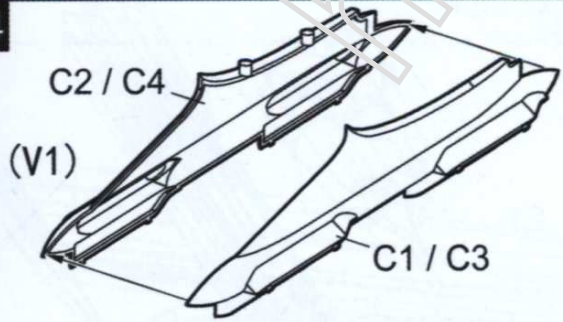

25

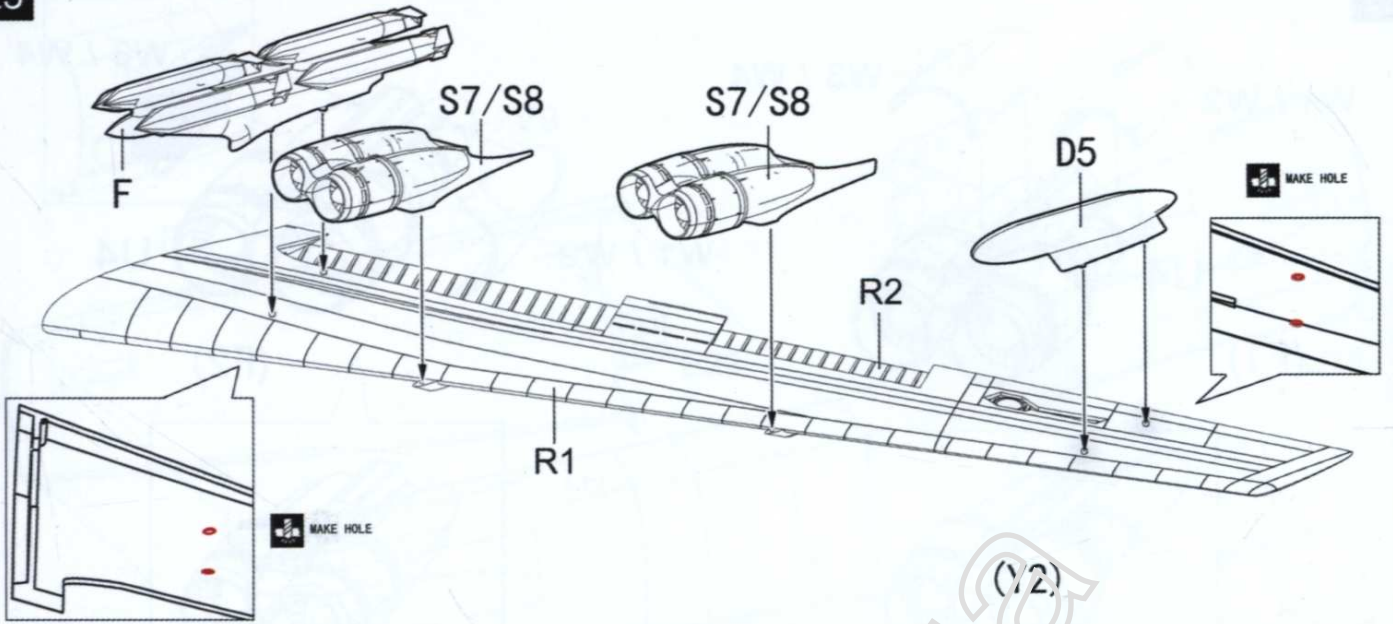

26

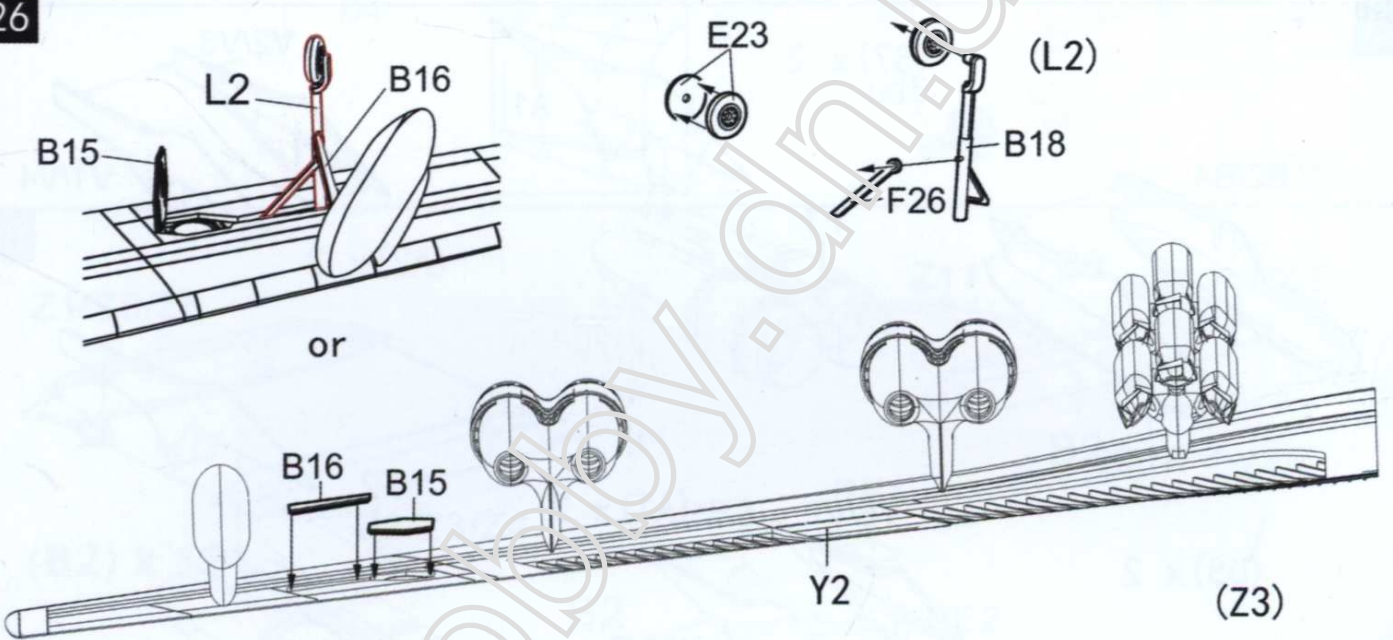

27

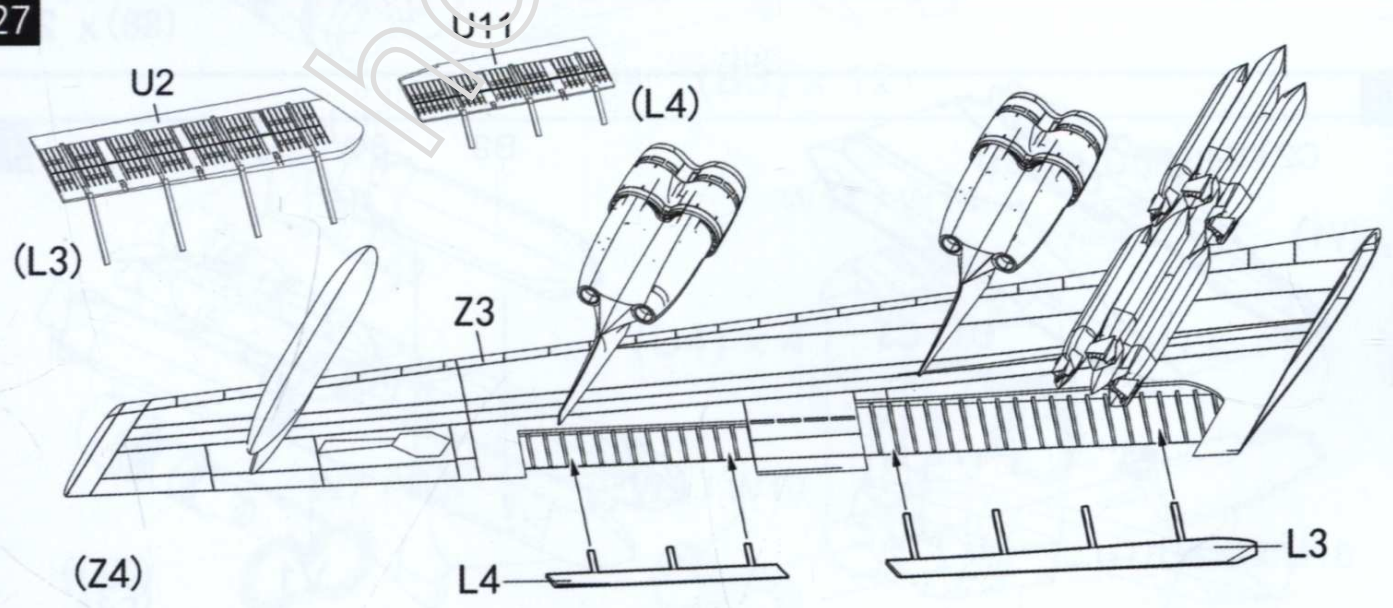

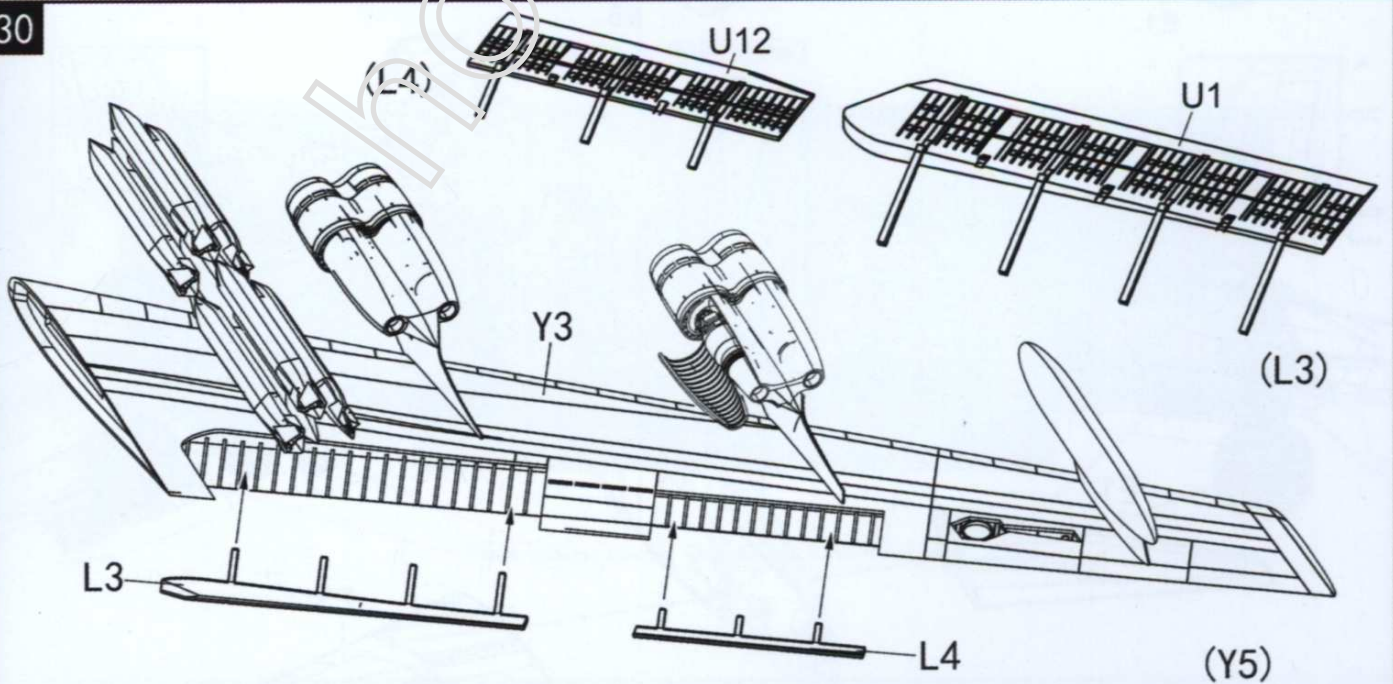
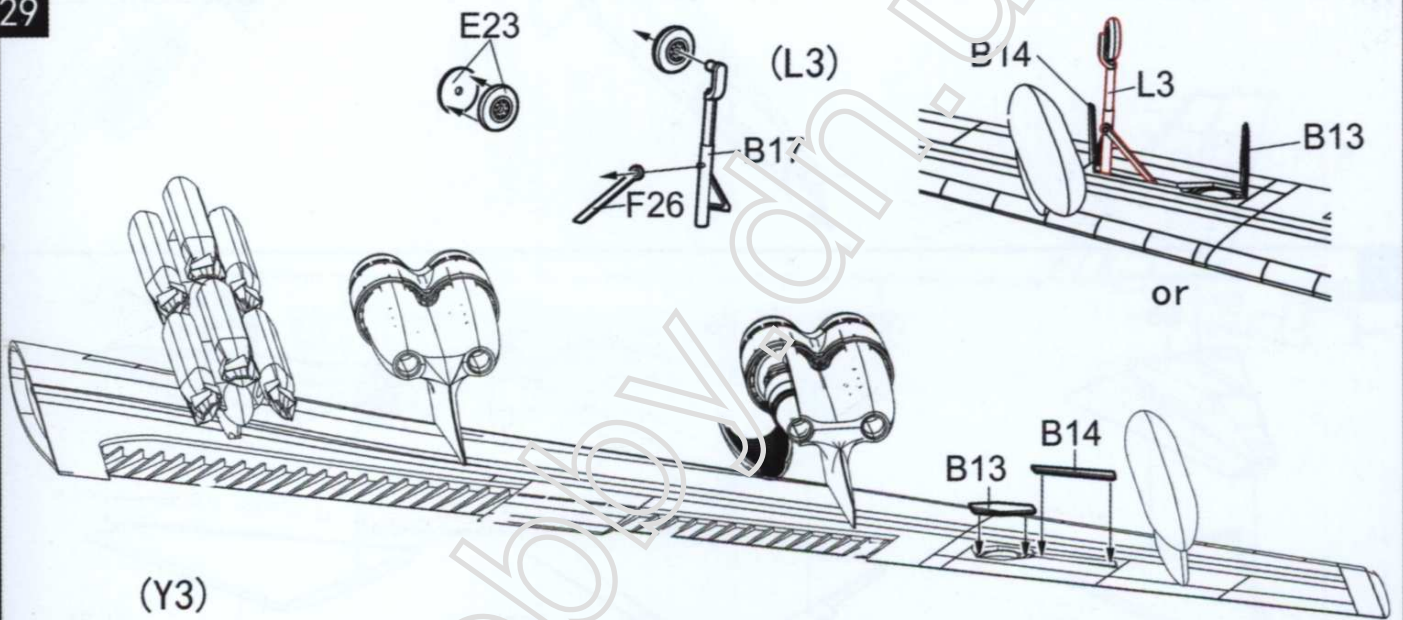
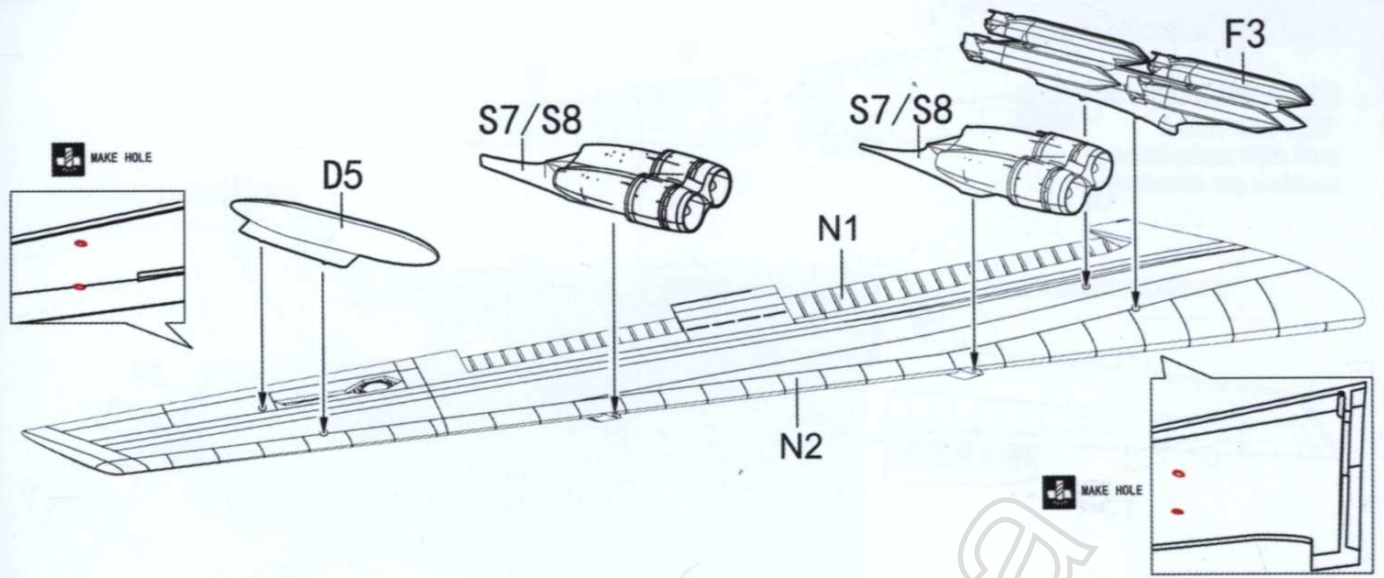

31

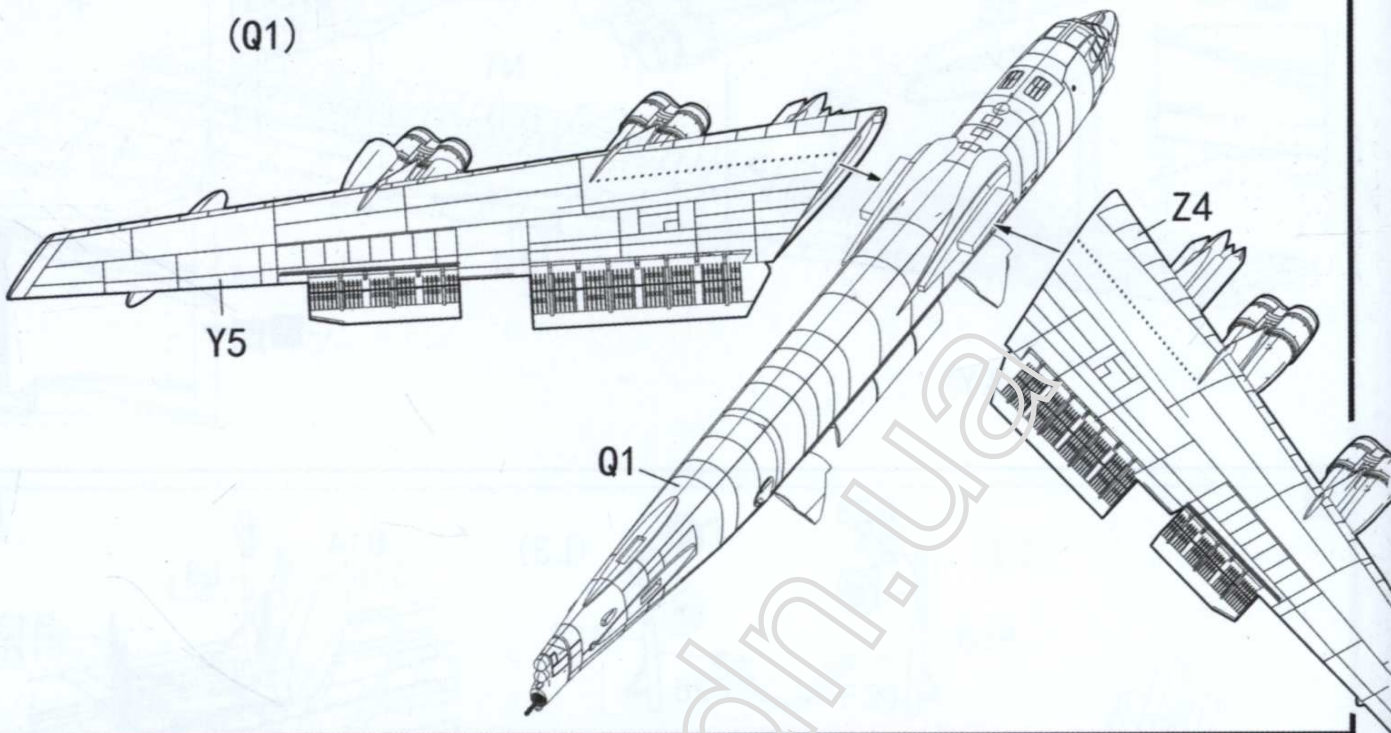
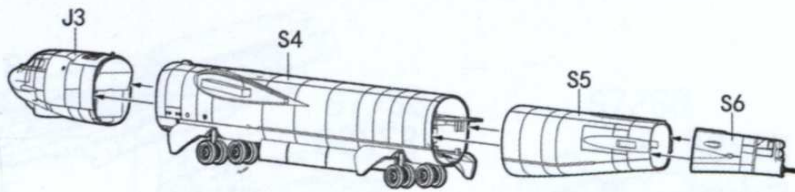

32

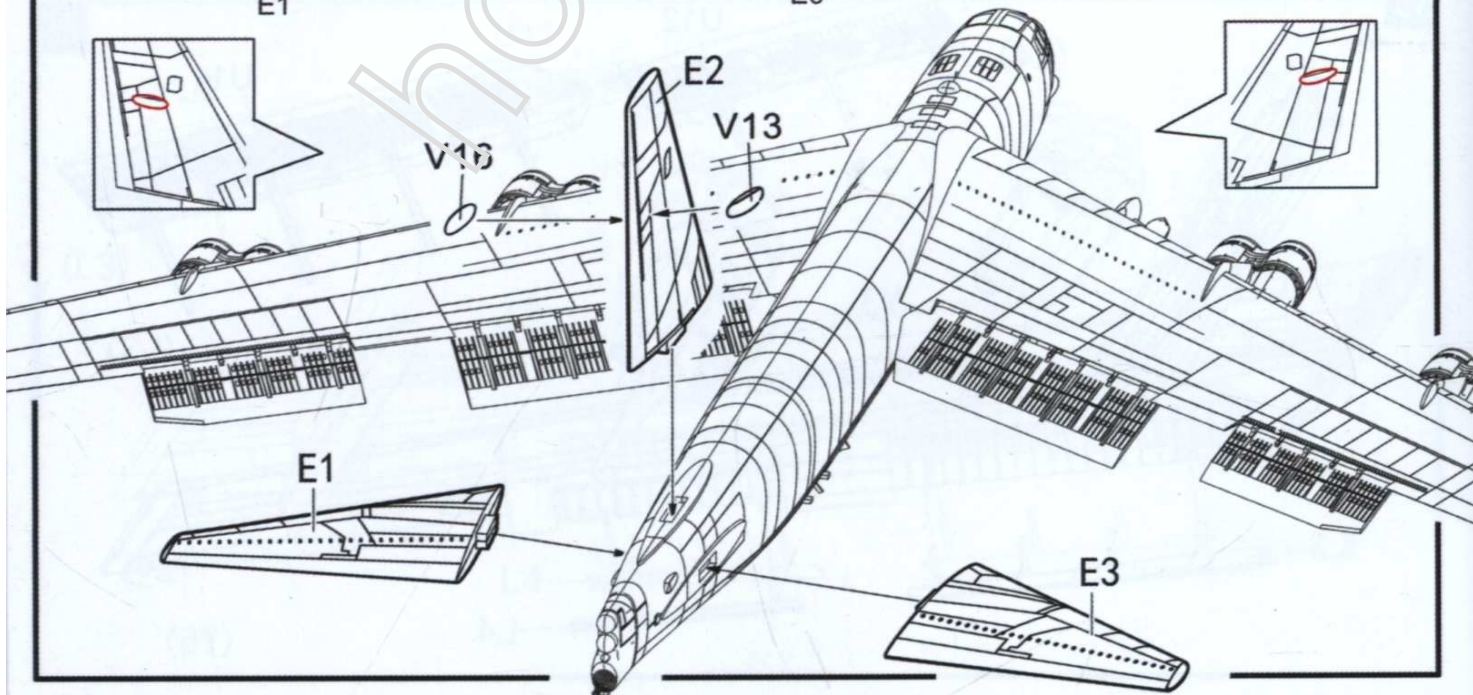
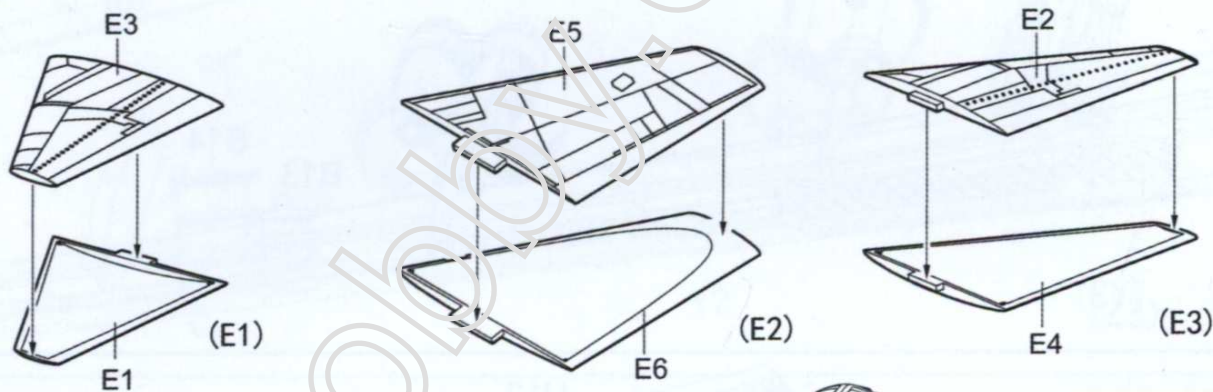

**DECALS AND COLOR SCHEME FOR
B-52H "SAC TIME"
93rd Bomb Squadron, 917th Wing
Barksdale AFB, Louisiana**

Interiors: A.MIG-205 Grey FS26173

Instruments: A.MIG-046 Black

Seats: A.MIG-205 Grey FS26173

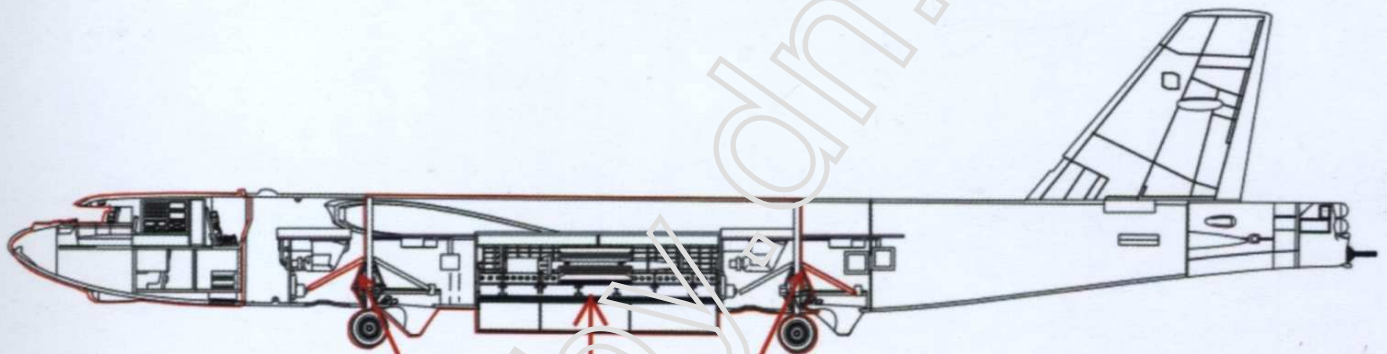
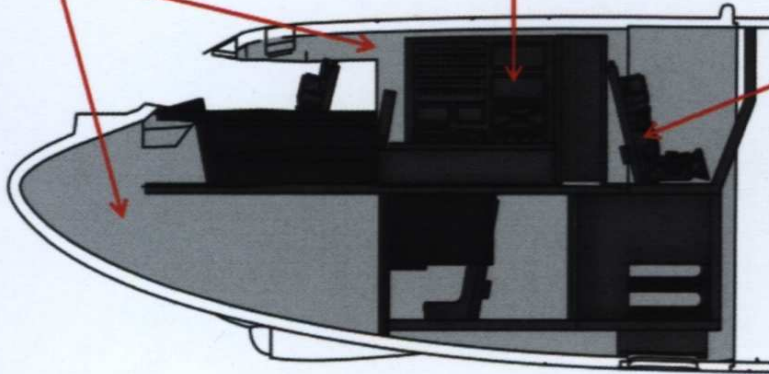

Wheel bay, fuselage and landing gear: A.MIG-047 Satin White

A.MIG-195 Silver

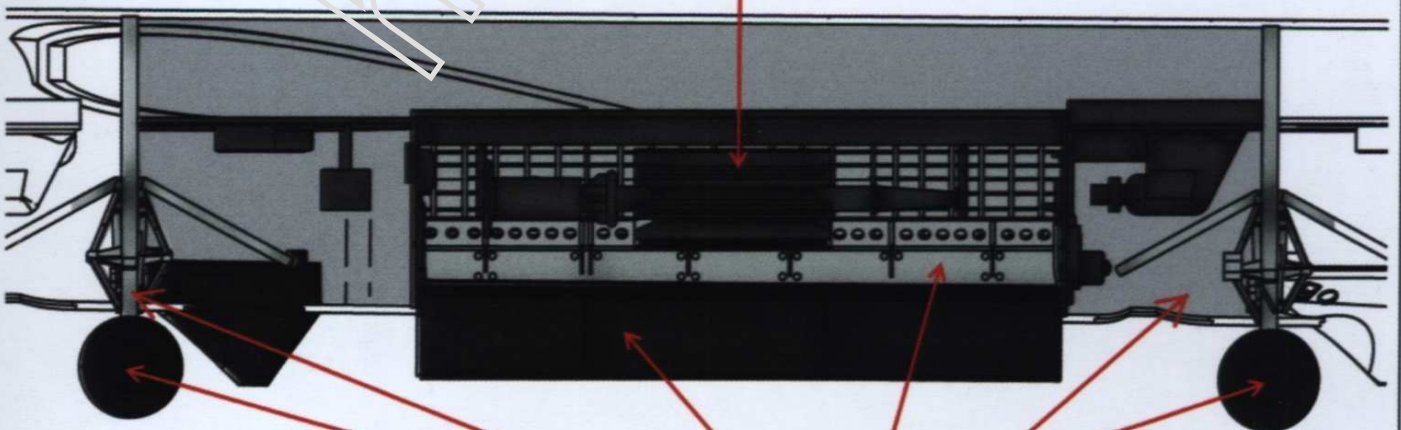

Wheels, wheel bay, bomb bay and landing gear: A.MIG-047 Satin White

U.S. AIR FORCE
SUBSONIC STRATEGIC BOMBER
BOEING B52-H
STRATOFORTRESS

modelcollect

DECALS AND COLOR SCHEME FOR
B-52H "SAC TIME"
93rd Bomb Squadron, 917th Wing
Barksdale AFB, Louisiana

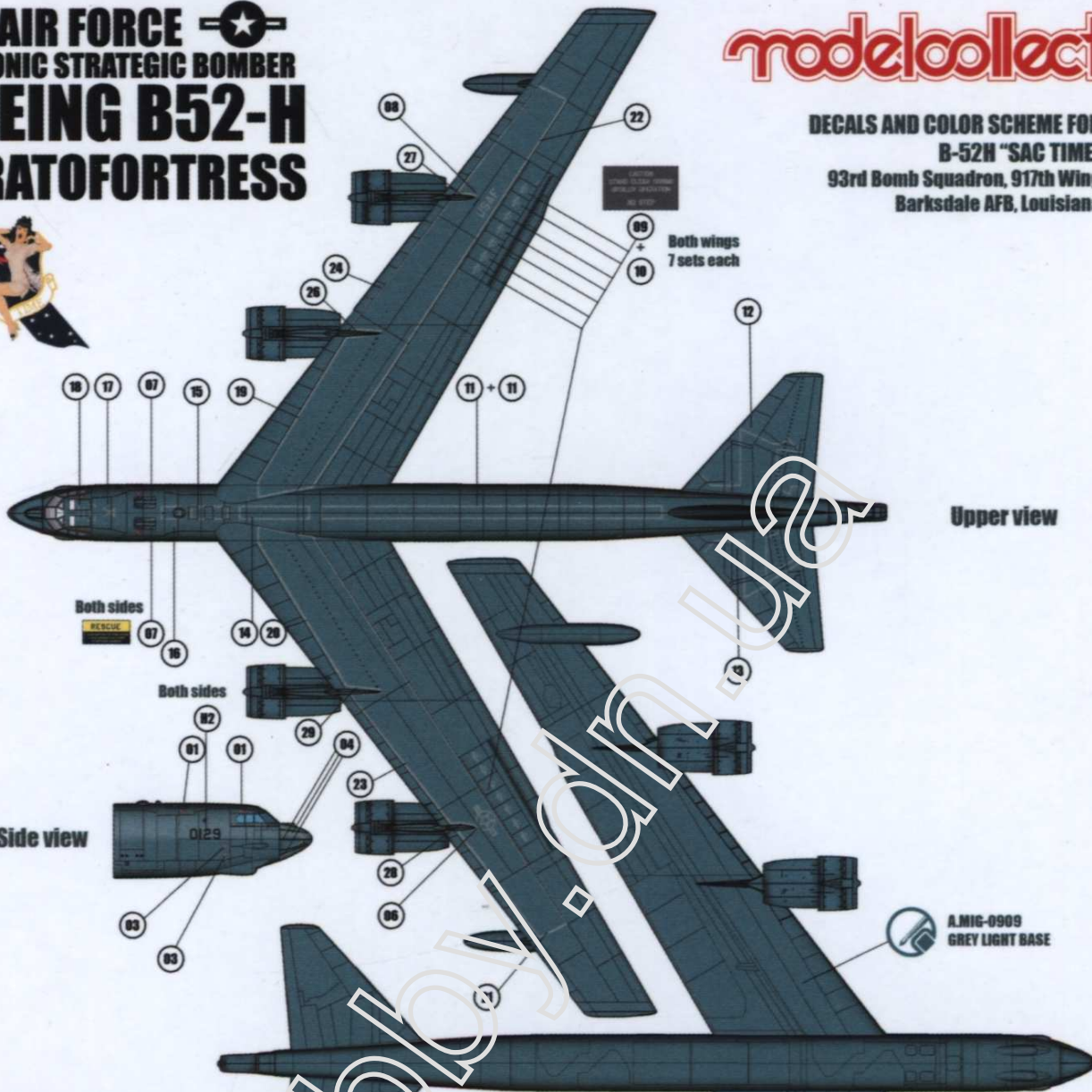

Upper view

Side view

Both sides

Both sides

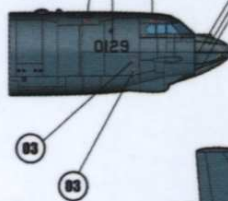

A.MIG-0909
GREY LIGHT BASE



A.MIG-0911 | LIGHT BASE

Bottom view

Checkers stripe goes in both sides. Use H6 for opposite one



Make your choice between the two options available

Both sides



Both sides



Select type

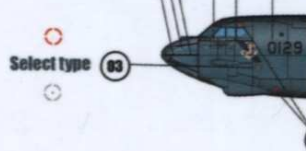

Select type

Both sides

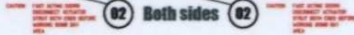

Jesus Jimenez Jimenez